



HO STRUCTURE KIT PLASTICS PELLET TRANSFER

933-3081

Thanks for purchasing this Cornerstone Series® kit. All parts are made of styrene, so use compatible glue and paint to finish your model. Please take a few minutes to read the instructions and study the drawings before starting construction.

Plastics play a huge role in our lives - so much so that it would be hard to imagine how we would get along with them! Plastics are actually synthetic polymers, created by causing a chemical reaction in an organic compound to alter its molecular structure. With a careful choice of starting materials, specific characteristics can be built in to the finished plastic. As a result, there are many, many different types with an incredible variety of uses. Plastics can be made hard, soft, clear, colored, opaque, rigid or flexible which allows them to be used in almost limitless ways.

The industry traces its roots to 1868, with the introduction of the first plastic, called "Celluloid" (actually cellulose nitrate) derived from cotton. It was first used commercially to make billiard balls, which had been carved from ivory. Designers quickly discovered Celluloid could be colored, molded and formed into various shapes. Among its many uses were costume jewelry, shirt collars, toys and motion picture film. Its greatest problem was that it proved to be highly flammable and unstable.

In 1908, an entirely new type of plastic was introduced, known by the trade-name "Bakelite." This was the first thermosetting plastic, which becomes hard when heated and can't be remelted. One of the most widely used of early plastics, it too could be molded and shaped to produce durable objects. Later types included melamine (still used to make unbreakable dishes) and epoxy resins, used for cement and as a hardener in paint.

The next major step was the development of thermoplastics, which soften when heated. Today, these are the most widely used and include such familiar names as polystyrene (known to modelers everywhere as "styrene"), polyethylene, nylon, polyvinyl chloride (PVC) and Teflon (PTFE).

Let's follow a batch of polystyrene (the plastic used in this kit) from start to finish. The first "ingredient" is styrene, made from petroleum by-products obtained in the refining process. To make plastic, we first stir the styrene with a catalyst, which begins a chemical reaction to restructure the styrene molecules (polymerization). This generates a lot of heat, so the styrene/catalyst is pumped into a water-cooled reactor. By the time it reaches the bottom of the reactor tank, it's heated to 329°F (200°C) and has polymerized into a hot, liquid plastic. This material is extruded into a water bath where it cools and solidifies. In the final step, the hardened plastic is machined into tiny pellets.

By themselves, the pellets are very light and easily moved with pneumatic systems. Since they're lightweight and large quantities are needed, pellets are often shipped long distance by train in specialized covered hoppers built for this service. On delivery, the pellets are once again unloaded by pneumatic systems and piped into storage tanks. From here, additional pipes carry the pellets to the molding machines.

A larger facility typically requires several types of plastics, along with various color concentrates (which may be in the form of pellets, liquids, pastes or powders) that will be mixed with the plastic. Additional additives, such as ultra-violet inhibitors to prevent fading and cracking when exposed to sunlight, or strengtheners to reduce breakage, may also be added.

This mixture is now ready for the automated injection molding machine. The pellets and additives are transferred into a heating chamber. When the mixture becomes liquid, a precise amount of material is injected under several tons of pressure into a metal mold, engraved with a pattern to produce a finished piece. Cooling channels on the outside of the mold are filled with oil or water, which absorbs the heat and forces the plastic to cool and harden. When the plastic parts have solidified, the mold opens and the finished piece is automatically pushed out by an ejector plate. The mold is then closed and the machine is ready to make another part.

Just as there are many kinds of plastics, there are many ways of molding them. Common methods include extrusion, where liquid plastic is forced through a shaped opening to produce sheets, tubes or rods. Blow molding is typically used to make plastic bottles, by blowing air into the center of a mold, forcing the hot plastic to stretch and fill the cavity. In vacuum-forming, commonly used for all kinds of product packaging, sheets of plastic are heated over a 3-D master in a vacuum chamber. The air is removed and the suction of the vacuum pulls the heated plastic over the master.

Modern plastics plants come in all shapes and sizes. The shop area is usually on the lowest floor as the molding machinery tends to be large and heavy. Size and capacity of the machinery is usually dictated by the size of the molds being run, with bigger machines needed to fill bigger molds. To be more efficient, several machines are usually running at the same time. Some operations also perform secondary steps, such as trimming, plating, labeling or decorating the finished plastic pieces. Storage space must be provided for raw materials, as well as finished pieces, along with receiving and shipping areas.

ON YOUR LAYOUT

With its detailed tanks, pipes and other details, your new Pellet Transfer Facility will add visual interest to any industrial area. Like the prototypes, it's designed to fit in small or odd-shaped spaces.

With its own siding, the model can be used as a stand-alone facility where pellets are transferred from train to truck for local delivery. This is an ideal trackside operation for layouts with limited space.

Look for these items and additional accessories to detail your new scene at your local hobby shop, or check out the complete selection of products at www.waltherscornerstone.com or in our latest HO Walthers Reference book.

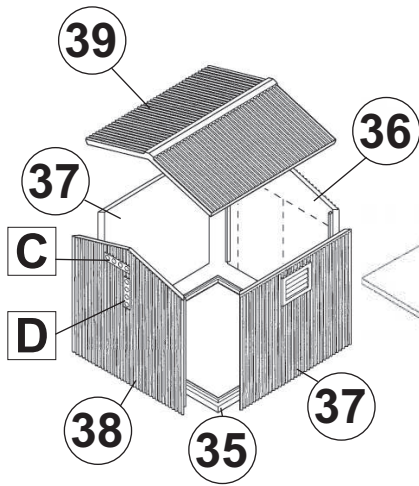

1. Glue the shed walls (36,37,38) together and to the base (35). Then glue the roof (39) on.

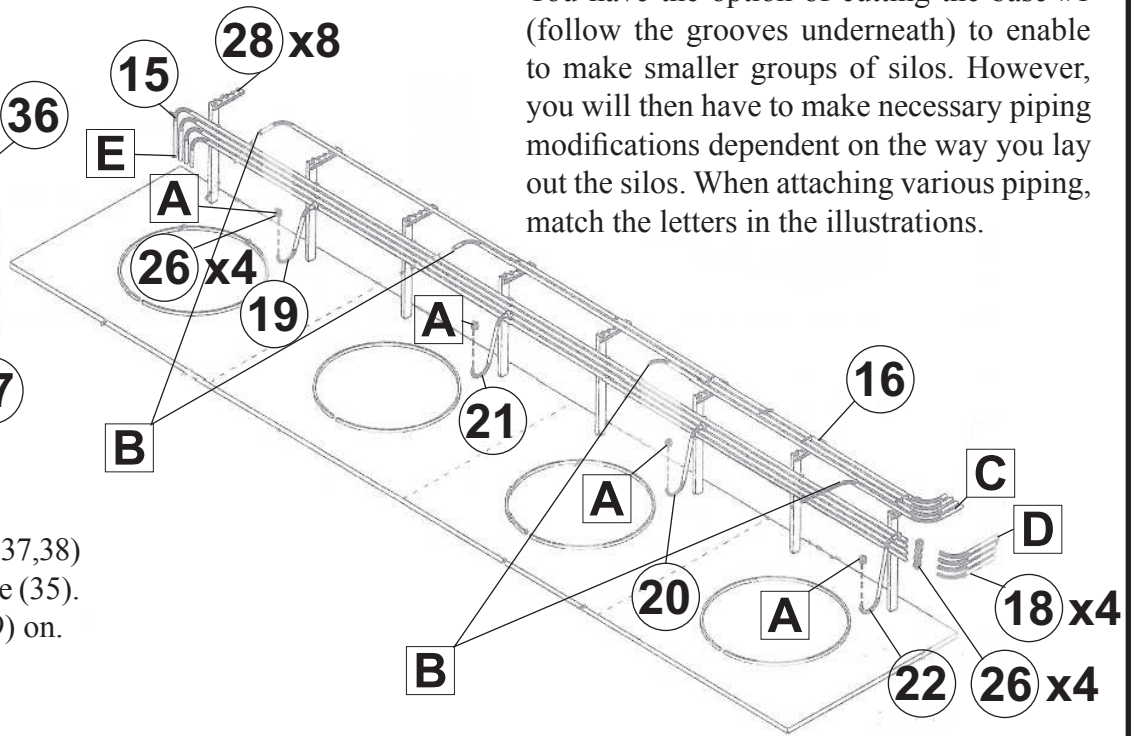

You have the option of cutting the base #1 (follow the grooves underneath) to enable to make smaller groups of silos. However, you will then have to make necessary piping modifications dependent on the way you lay out the silos. When attaching various piping, match the letters in the illustrations.

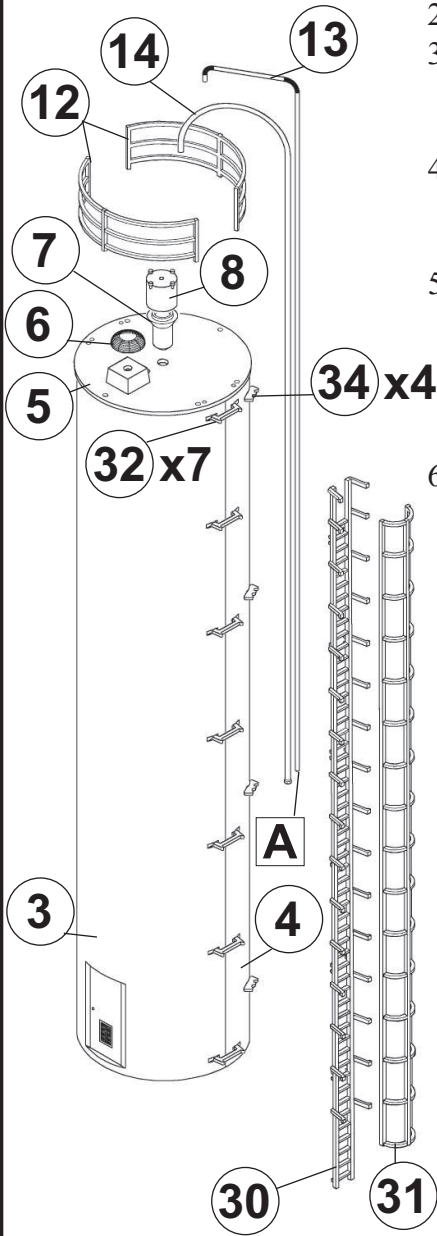

2. Glue the pipe supports (28) into the base (1).
3. Glue pipe assembly #15 onto the sides of the supports, above the peg on each support. Have the pipes extend 5mm (13/64") past the support on the right side.
4. Glue the top pipe assembly (16) on top of the supports. Each individual pipe fits between the notches on the support, with the right cross bracing on #16 going 1mm (3/64") to the left of the far right support.
5. Glue the flanges (26) onto the bottoms of the loading pipes (19,20,21,22). Then starting from the left side, glue the pipes to their respective places on pipe #15. Note: Pipe #19 is the shortest and goes on the bottom pipe of #15 on the far left. Then comes #21 and #20 with #22 being the tallest, attaching to the top pipe of #15 on the far right.
6. Glue the flanges (26) onto the ends of #15 and then glue the angled pipes (18) into the other ends of the flanges. Note: The curved end goes into the flange.
7. Glue the silo halves (3,4) and top (5) together.
8. Glue the pipe brackets (34) in the grooves on part #4.
9. Next, on only one silo, glue the ladder brackets (32) in the grooves along the joint of both silo halves.
10. Glue the vents (6,7,8) in their respective places on the roof.
11. Glue the railings (12) into the holes on the roof.
12. Glue the rounded pipe (14) into the hole on the top of the roof and in the grooves in the pipe bracket closest to the silo joint. Then glue the angular pipe (13) into the top of part #8 and the other groove in the pipe bracket.
13. Glue the ladder (30) and cage (31) together and to the ladder brackets.
14. Glue one pipe (17) into half #4 of each silo. Glue a flange (26) onto the top of each pipe.

15. Glue the pipe supports (29) to both bases (2).

16. On the first base #2, the one on the right in the illustration, glue pipe #23 onto the top hanger of the support, centering the outlets between the supports. Glue pipe #40 on the lower hanger of the support, making sure the ends line up with pipe #23.

17. You have the option of attaching a "tee" (24) or an elbow (25) on the end of pipe #23. Glue the flanges on to the desired piece as shown and then glue on pipe #27.

18. On the second base #2, glue Pipe #40 on to the top hanger and pipe #23 on the lower one. Glue a flange on to the right ends of both pipes and then glue the pipes from both bases (2) together.

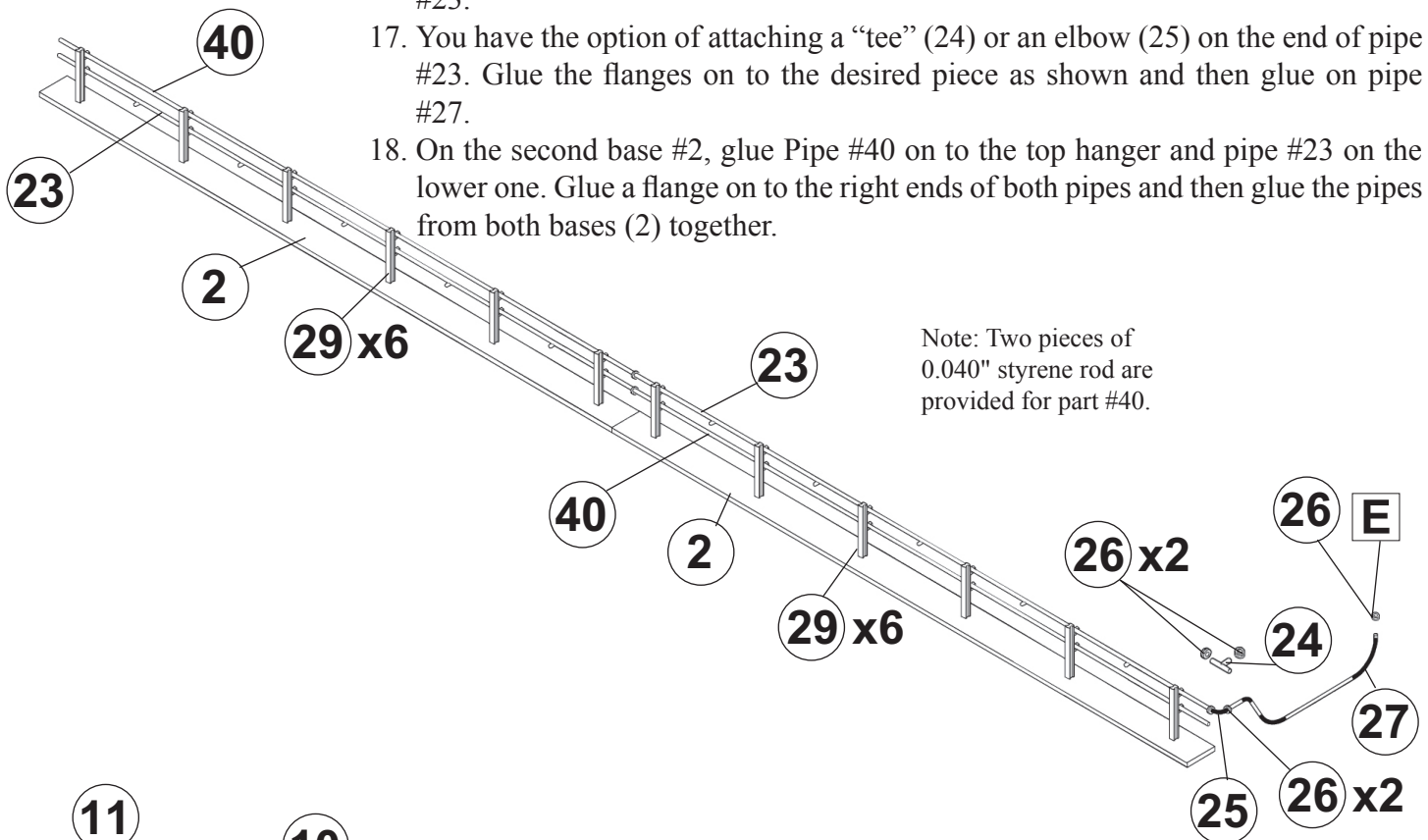

Note: Two pieces of 0.04" styrene rod are provided for part #40.

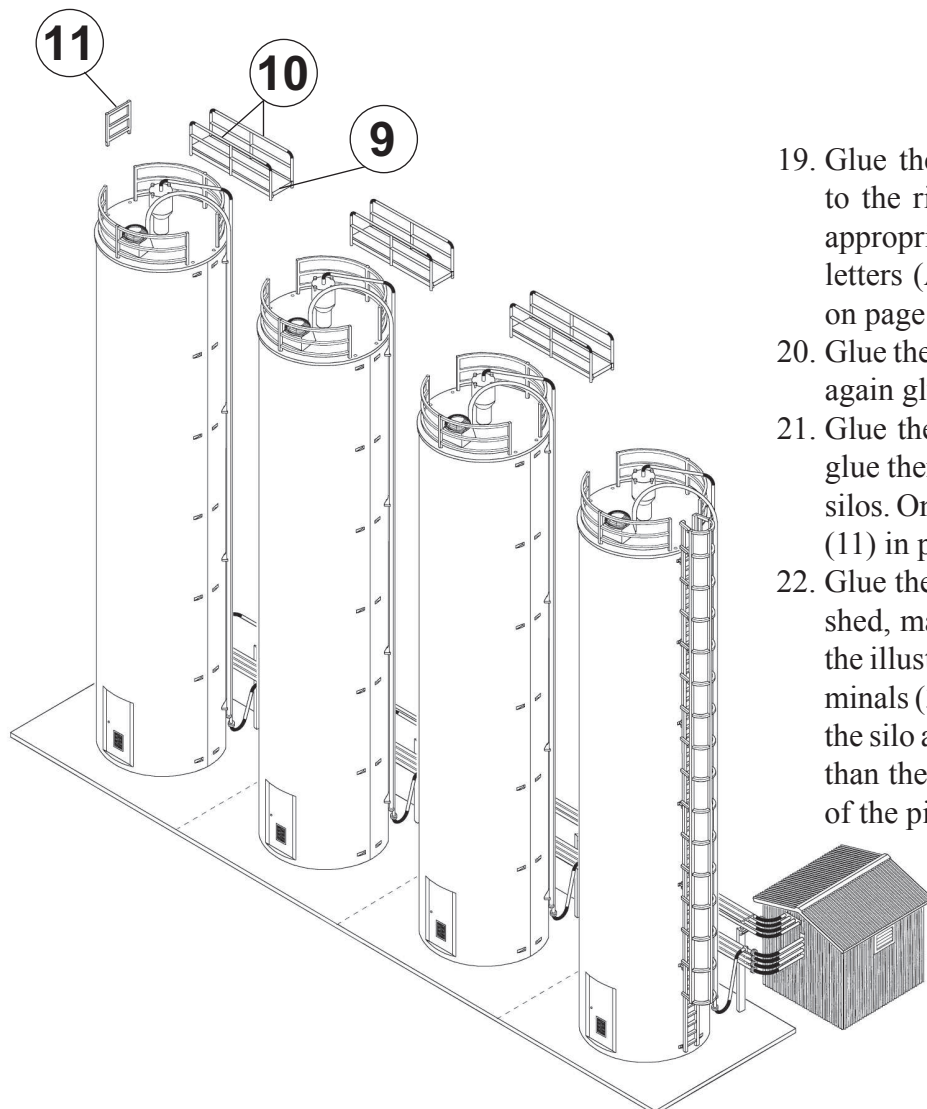

19. Glue the completed silo with the ladder on to the right side of the base (1), gluing the appropriate piping together. Note: Match the letters (A & B) as shown in the illustrations on page 2.

20. Glue the other completed silos to the base (1), again gluing the appropriate piping together.

21. Glue the gangways (9,10) together and then glue them into the holes on the tops (5) of the silos. On the far-left silo, glue the small railing (11) in place.

22. Glue the pipes to the correct locations on the shed, matching the letters (C & D) shown in the illustrations on page 2. Note: The pipe terminals (33) are to be used if you wish to attach the silo assembly to a different structure, other than the shed. Glue the terminals to the ends of the pipes and then to the structure's wall.

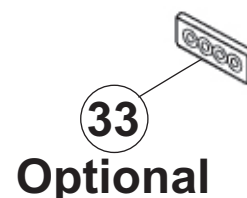

Optional

23. To complete, place the piping group next to the silo assembly as shown and glue pipe #27 to one of the pipes marked E (see illustrations on page 2 and 3).

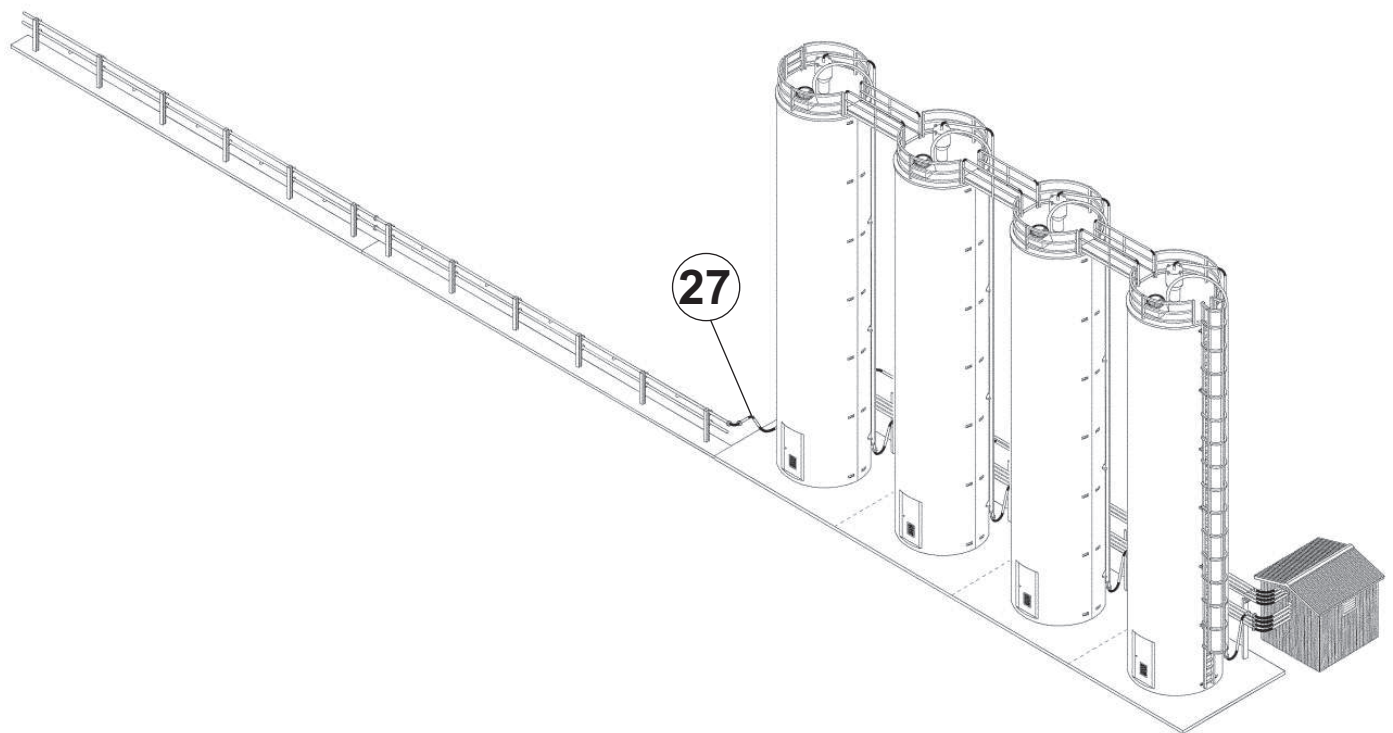

DECALING

1. After cutting out the decal, dip in water for 10 seconds, remove and let stand for 1 minute. Slide decal onto surface, position and then blot off any excess water.
2. Lightly brush on Micro Sol® on top. This will soften the decal allowing it to conform to irregular surfaces. **DO NOT TOUCH DECAL** while wet!
3. When the decal is thoroughly dry, check for any trapped air bubbles. Prick them with the point of a small pin or hobby knife blade and apply more Micro Sol®.