

# SCHLOSSEREI

FITTER'S SHOP  
SERRURERIE  
METAALBEDRIJF



Art. Nr. 130192

**D**

Vor Beginn des Bastelns sollten Sie sich mit den Spritzlingen und der Anleitung vertraut machen. Sollte es einmal vorkommen, dass ein Teil im Bausatz fehlt, kreuzen Sie bitte das fehlende Teil in der Anleitung an und schicken Sie diese bitte an Fa. Gebr. FALLER GmbH, Abt. Kundendienst, kundendienst@faller.de, Kreuzstraße 9, 78148 Gütenbach. Sie erhalten dann umgehend Ersatz. Es kann vorkommen, dass bei einem Bausatz Einzelteile übrig sind.

**GB**

Before beginning with the assembly please familiarize yourself with the parts and read the instructions carefully. In case of missing parts please indicate these on the instructions leaflet with a circle and return the leaflet to Gebr. FALLER GmbH, kundendienst@faller.de, Kreuzstraße 9, D-78148 Gütenbach, Germany. You will receive the replacement by return. It may happen, that in a kit single parts are not being used.

**F**

Avant de commencer le montage de votre maquette bien lire la notice et repérer les grappes. Si une pièce manque dans une boîte, cochez la pièce correspondante sur la notice et renvoyez-la-nous à Gebr. FALLER GmbH, kundendienst@faller.de, Kreuzstraße 9, D-78148 Gütenbach (R.F.A.). Nous vous ferons parvenir la pièce par retour. Dans certains kits, il est possible que certaines pièces ne soient pas utilisées.

**NL**

Vóór het bouwen zou men de gietstukken en de handleiding moeten bestuderen. Indien onverhoopt een onderdeel aan het bouwpakket ontbreekt, gelieve men het ontbrekende deel in de handleiding aan te kruisen en deze te zenden aan Gebr. FALLER GmbH, kundendienst@faller.de, Kreuzstraße 9, D-78148 Gütenbach. U ontvangt dan omgaand en gratis het ontbrekende onderdeel. Het kan voorkomen dat u bij bepaalde bouwdozen onderdelen overhoudt.

Für den Zusammenbau des Modells empfehlen wir folgende FALLER-Artikel (sind nicht im Bausatz enthalten):  
For the assembly of the kit we recommend following FALLER products (not included in the kit):  
Pour l'assemblage du modèle, nous vous recommandons les articles FALLER suivants (non inclus dans le kit):  
Om dit model te bouwen adviseren wij de volgende FALLER producten (maken geen deel uit van deze bouwset):



Art. Nr. 170492  
FALLER-EXPERT

Flüssigkleber in Plastikflasche mit Spezialkanüle für feinste Klebstoffdosierung.

Liquid cement in plastic bottle with canule for very fine dosage.

Cette liquide en bouteille plastique avec bec verseur pour un dosage précis.

Vloeibare lijm in plastic-flescon met doseerbuisje om nauwkeurig te lijmen.



Art. Nr. 170688  
SPEZIAL-SEITENSCHNEIDER

zum gratfreien Abtrennen von feinsten Spritzteilen.  
Nur für Polystyrol geeignet.

Special side cutter for cutting off ultra-fine moulded parts without burrs.  
Only suitable for polystyrene.

Pince coupants spéciale pour couper sans bavure les pièces miniatures moulées par injection. Convient uniquement au polystyrène.

Speciale zijknijptang voor het braamloos afknippen van de fijnste gietstukdelen. Alleen geschikt voor polystyrol.

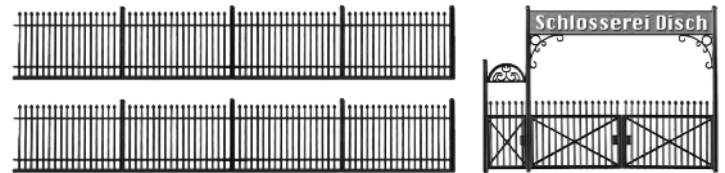

<b>Inhalt</b>	Spritzlinge	1 A	1 x	2 C	1 x	8 A	1 x	12 A	2 x	05	1 x
<b>Contents</b>	Sprues	1 B	1 x	3 AB	1 x	9 B	2 x	12 B	1 x	8	1 x
<b>Contenu</b>	Moulagés	2 A	1 x	4 B	1 x	10 C	1 x	13 C	1 x		
<b>Inhoud</b>	Gietstukken	2 B	1 x	6	1 x	11 C	2 x	01	1 x		

Sa. Nr. 130 192 1

2

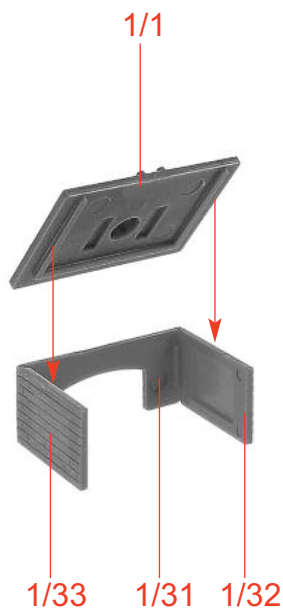

Papiermaske  
 Papermask  
 Masque  
 Masker **M1**

**A**

1/33 1/31 1/32

**B**

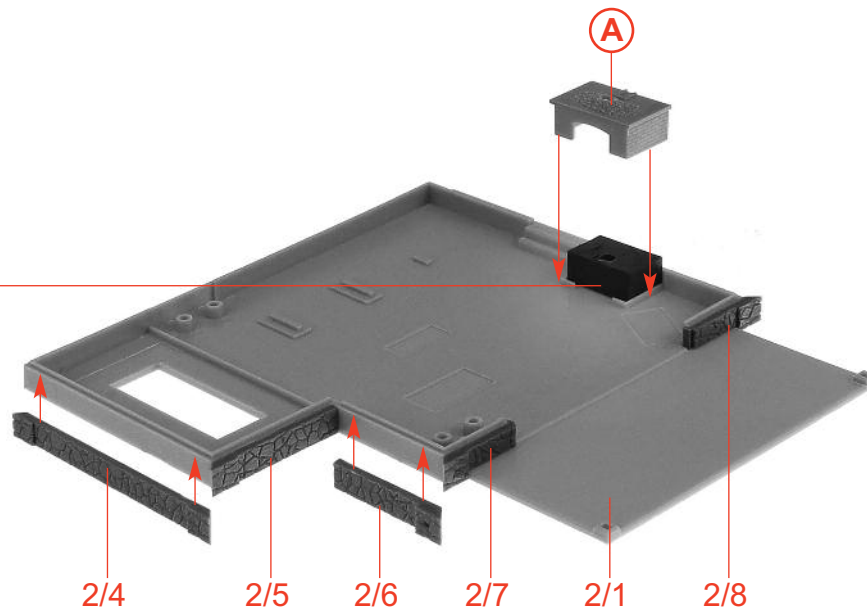

**A**

2/4 2/5 2/6 2/7 2/1 2/8

**B**

2/12

Sekundenleber (FALLER EXPERT rapid 170500) verwenden.  
 Use instant modelling cement (FALLER EXPERT rapid 170500).  
 Utilisez la colle rapide (FALLER EXPERT rapid 170500).  
 Gebruik secondenlijm (FALLER EXPERT rapid 170500).

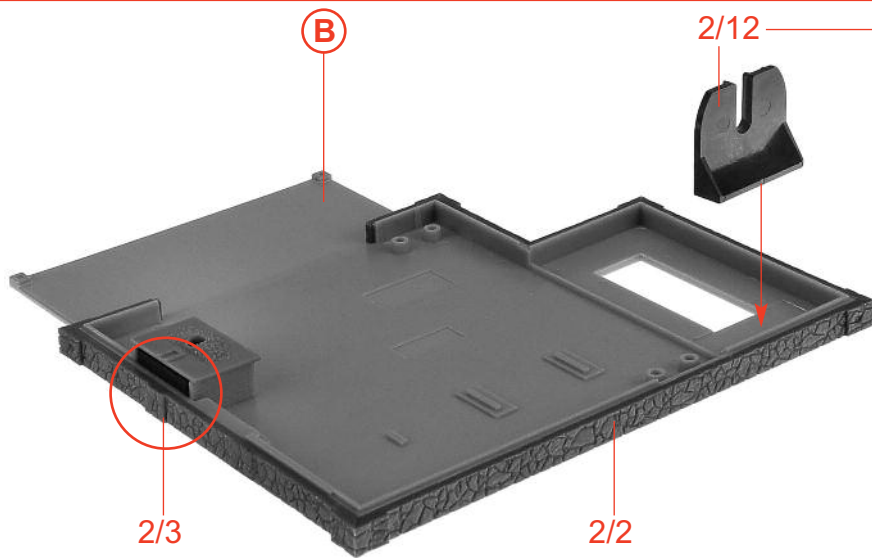

**C**

2/3 2/2

Sollten sich die Teile 2/18 zu stramm auf die Welle schieben lassen, können Sie mit Hilfe einer Dreikantstielfeile Kerben in die Bohrung feilen (siehe Skizze) und den entstehenden Grat entfernen. Anguss sauber entfernen (Riemenlauffläche)!

Should parts 2/18 be fastened too tightly on the shaft, you may cut some notches within the hole using a triangular file (see sketch) and remove the burr produced. Cleanly remove the sprue (belt running surface)!

Au cas où il serait trop difficile de faire glisser les pièces 2/18 sur l'arbre, vous pouvez limer des encoches dans le trou de la pièce à l'aide d'une lime triangulaire (voir croquis) et supprimer la bavure produite. Éliminer proprement le culot (bande de roulement de la courroie) !

Als de delen 2/18 te strak op de as schuiven kunt u met behulp van een driekante vijl kerven in de boorgaten vijlen (zie schets) en daarna de ontstane bramen verwijderen. Gietbramen helemaal verwijderen (loopvlak voor de riemen)!

3 x 2/18

3

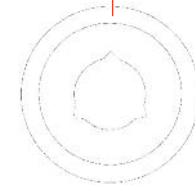

<b>Inhalt</b>	Tüte 1
<b>Contents</b>	bag 1
<b>Contenu</b>	sachet 1
<b>Inhoud</b>	zakje 1

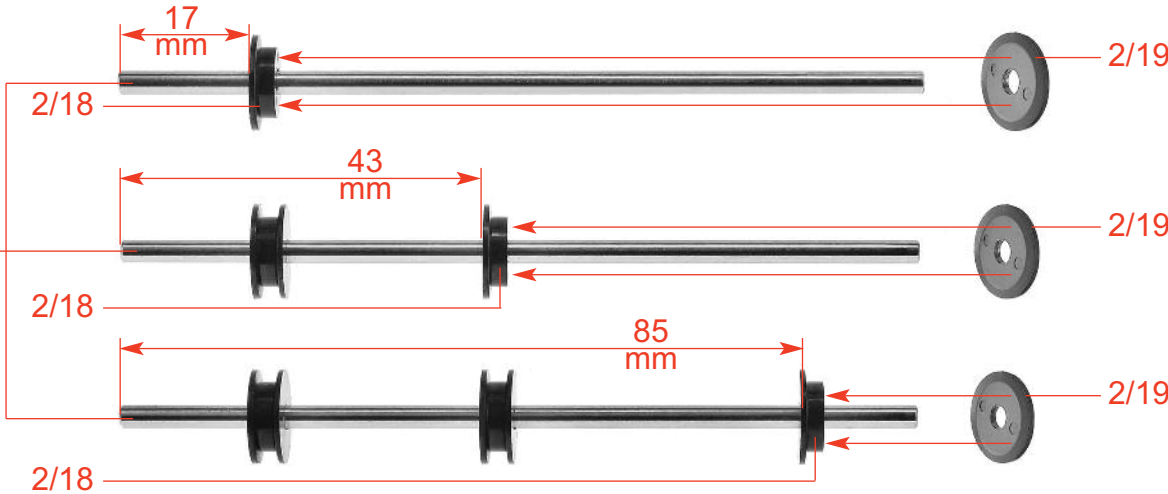

Mit Sekundenkleber fixieren.  
Achtung: nicht auf die Welle kleben.

Secure with instant adhesive.  
Caution: do not glue to the axle.

Immobiliser au moyen de colle instantanée. Attention : ne pas coller sur l'arbre.

Met secondelijm fixeren.  
Let op: niet op de as lijmen.

**D**

Kugellager bündig auf die Wellenenden pressen, nicht auf die Welle kleben!

Presser les roulements à billes sur les extrémités de l'arbre de façon qu'ils affleurent, ne pas les coller sur l'arbre !

Press the ball-bearings on the axle so that they are flush with the axle ends, do not glue them to the axle!

Kogellagers stevig op de as uiteinden drukken en niet op de as lijmen!

Sekundenkleber

**E**

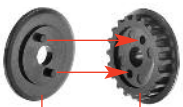

2/16 2/15

**F**

<b>Inhalt</b>	Tüte 1
<b>Contents</b>	bag 1
<b>Contenu</b>	sachet 1
<b>Inhoud</b>	zakje 1



2/17

**D**

**E**

<b>Inhalt</b>	Tüte 1
<b>Contents</b>	bag 1
<b>Contenu</b>	sachet 1
<b>Inhoud</b>	zakje 1

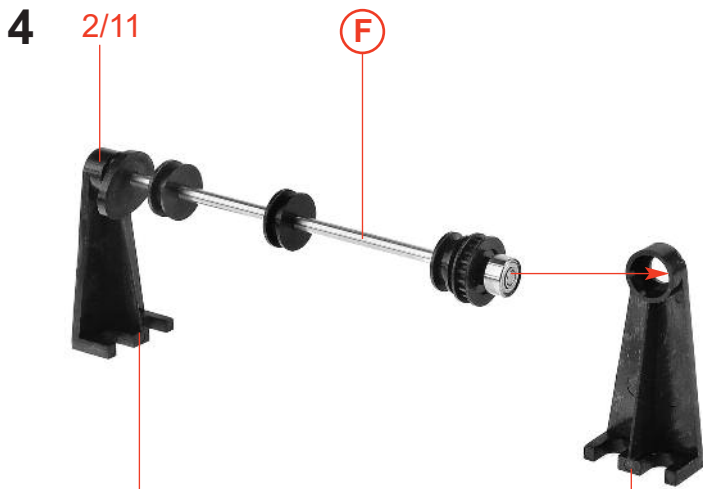

nicht kleben  
do not glue  
ne pas coller  
niet lijmen

**G**

2/11

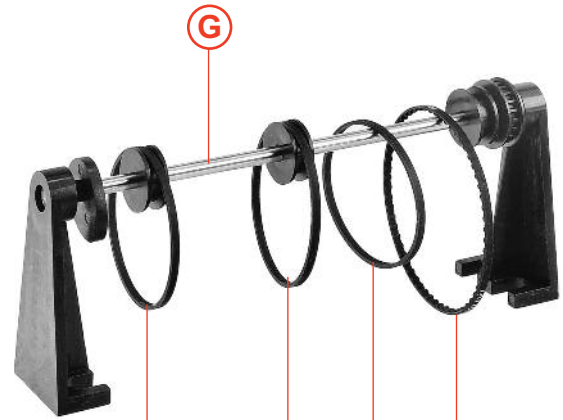

nicht kleben  
do not glue  
ne pas coller  
niet lijmen

**H**

<b>Inhalt</b>	Tüte 2	<b>Contents</b>	bag 2
<b>Contenu</b>	sachet 2	<b>Inhoud</b>	zakje 2

<b>Inhalt</b>	Tüte 1	<b>Contents</b>	bag 1
<b>Contenu</b>	sachet 1	<b>Inhoud</b>	zakje 1

nicht kleben  
do not glue  
ne pas coller  
niet lijmen

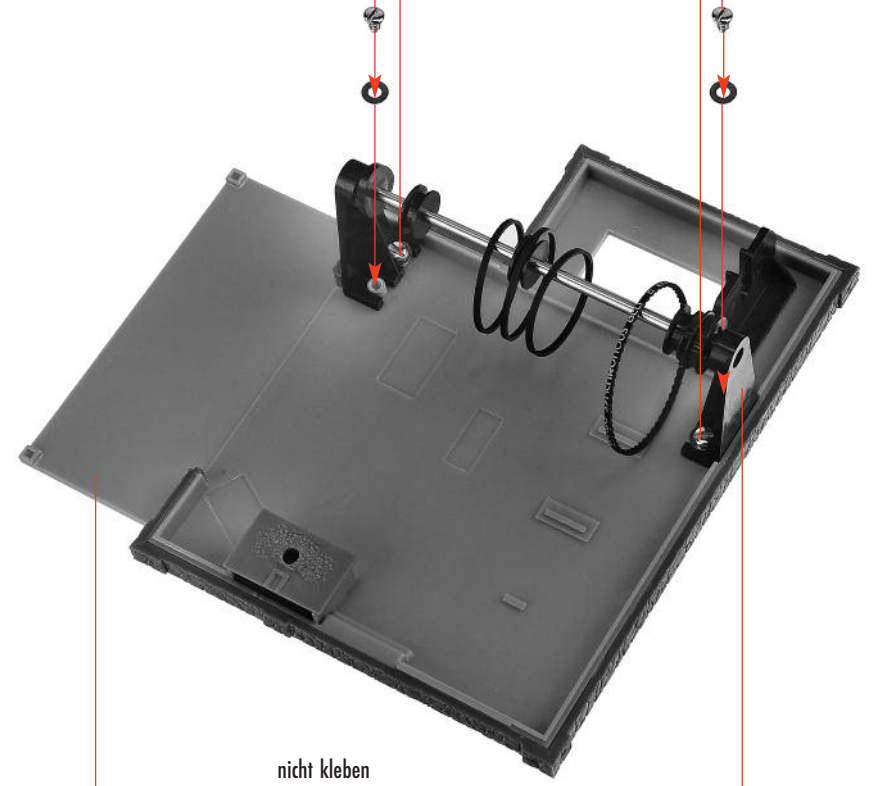

nicht kleben  
do not glue  
ne pas coller  
niet lijmen

**I**

**C**

**H**

Sekundenkleber verwenden.  
Use instant modelling cement.  
Utilisez la colle rapide.  
Gebruik secondenlijm.

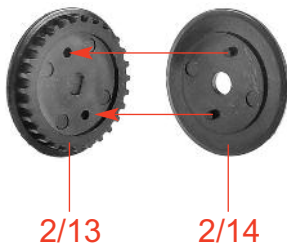

2/13

2/14

J

<b>Inhalt</b>	Tüte	<b>Contents</b>	bag
<b>Contenu</b>	sachet	<b>Inhoud</b>	zakje

K

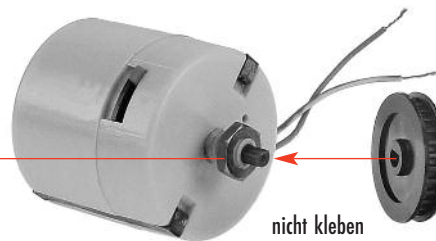

nicht kleben  
do not glue  
ne pas coller  
niet lijmen

J

Zahnriemen einhängen und Motor mit geringer Riemenspannung festschrauben.  
Auf Motorlaufrichtung achten!

Hang the toothed belt and screw the motor so that the belt shows only minute tension.  
Make sure the motor shows the right rotating direction!

Accrocher la courroie crantée et visser le moteur de façon à ce que la courroie présente une faible tension.  
Prêter attention au sens de rotation du moteur !

Tandriem bevestigen en motor met geringe riemspanning vastschroeven.  
Let op de looprichting van de motor!

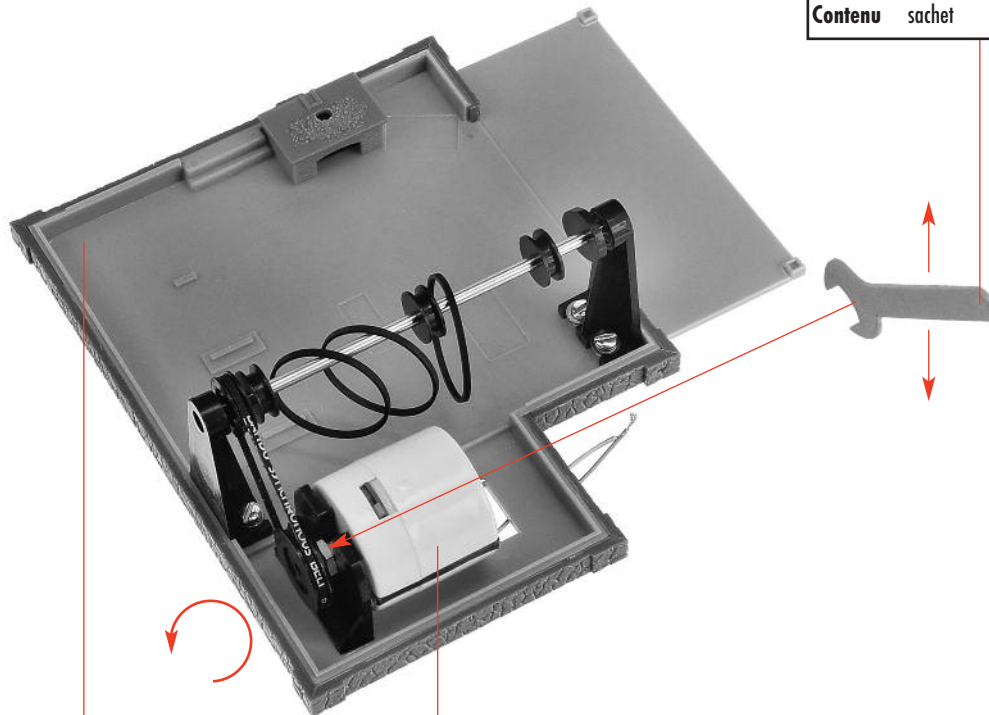

<b>Inhalt</b>	Tüte	<b>Contents</b>	bag
<b>Contenu</b>	sachet	<b>Inhoud</b>	zakje

L

I

K

- 6** Alle beweglichen Teile müssen absolut gratfrei und leichtgängig sein.  
 All moving parts must be absolutely free from burrs and show smooth motion.  
 Toutes les pièces mobiles doivent être absolument sans aucune bavure et tourner facilement.  
 Alle bewegende delen moeten absoluut vrij van bramen zijn en licht lopen.

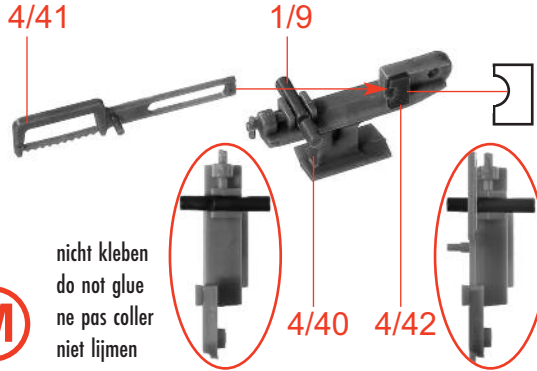

**M**

nicht kleben  
do not glue  
ne pas coller  
niet lijmen

**N**

nicht kleben  
do not glue  
ne pas coller  
niet lijmen



**M** 1/10

Nur an dieser Stelle kleben.  
Only apply glue to this point.  
Coller exclusivement cet emplacement.  
Alleen op deze plaats lijmen.

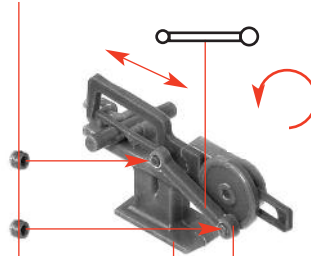

**O**

1/4

**N** 1/5



**P**

**O**

Mit Sekundenkleber kleben und entgraten! Riemenlauffläche!  
 Secure with instant adhesive and deburr! Running surface!  
 Fixer avec une colle instantanée et ébarber ! Bande de roulement !  
 Met secondelijm lijmen en ontbramen! Riemenloopvlakken

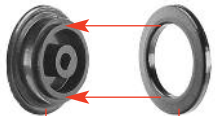

**Q**

2/23

2/24

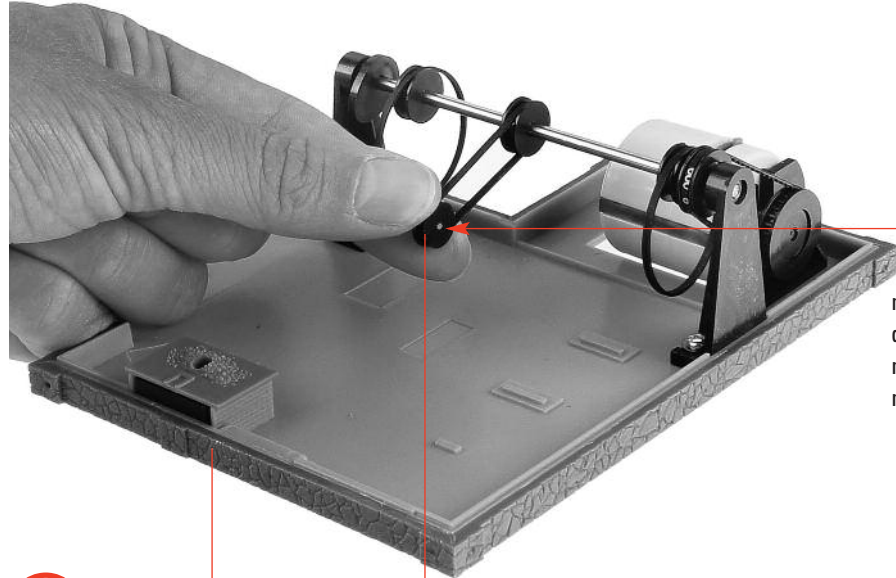

**R**

**L**

**Q**

nicht kleben  
do not glue  
ne pas coller  
niet lijmen

**P**

Mit Sekundenkleber kleben und entgraten! Riemenlauffläche!  
 Secure with instant adhesive and deburr! Running surface !  
 Fixer avec une colle instantanée et ébarber ! Bande de roulement !  
 Met secondelijm lijmen en ontbramen! Riemenloopvlakken

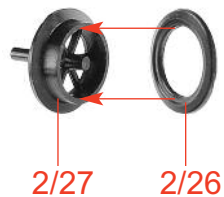

**S**

2/27 2/26

nicht kleben  
 do not glue  
 ne pas coller  
 niet lijmen



**S**  
**T**



**T**  
**U**

Nur an dieser Stelle kleben.  
 Only apply glue to this point.  
 Coller exclusivement cet emplacement.  
 Alleen op deze plaats lijmen.

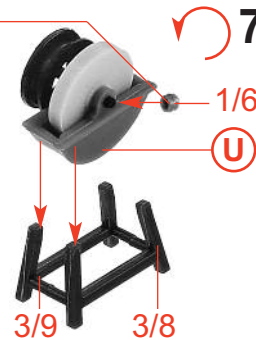

**V**

**7**

nicht kleben  
 do not glue  
 ne pas coller  
 niet lijmen

<b>Inhalt</b>	Tüte 1
<b>Contents</b>	bag 1
<b>Contenu</b>	sachet 1
<b>Inhoud</b>	zakje 1

20 mm

**a**

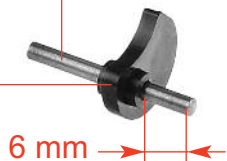

6 mm

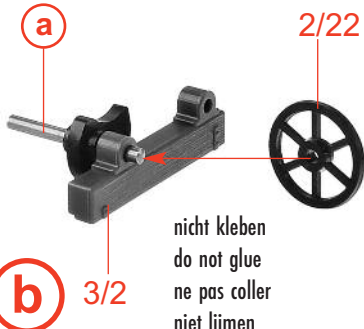

**b**

nicht kleben  
 do not glue  
 ne pas coller  
 niet lijmen

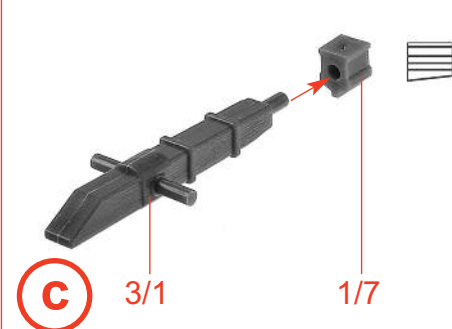

**c**

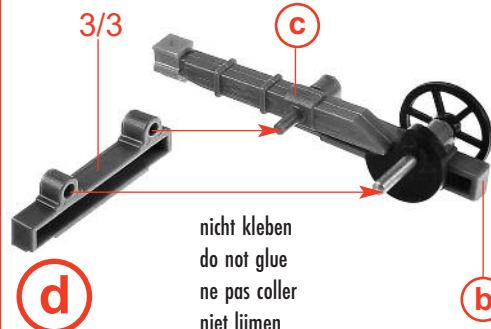

**d**

nicht kleben  
 do not glue  
 ne pas coller  
 niet lijmen

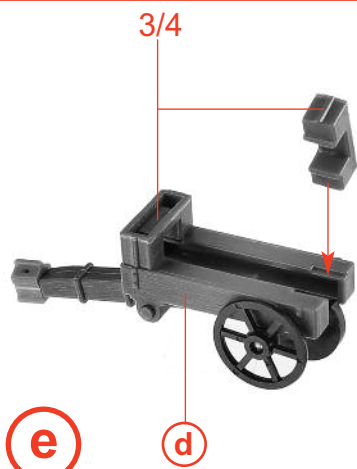

**e**

**d**

Mit Sekundenkleber kleben und entgraten! Riemenlauffläche!  
 Secure with instant adhesive and deburr! Running surface!  
 Fixer avec une colle instantanée et ébarber ! Bande de roulement !  
 Met secondelijm lijmen en ontbramen! Riemenloopvlakken

**f**

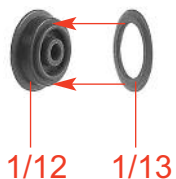

1/12 1/13

Achtung: der Hammer muss sich so leicht bewegen lassen, dass er von seinem Eigengewicht herunter fällt.  
 Caution: the hammer must move so easily that it falls down by its own weight.  
 Attention : le mouvement du marteau doit être si facile qu'il tombera de son propre poids.  
 Let op: de hamer moet zo licht bewegen dat deze door zijn eigen gewicht naar beneden valt.

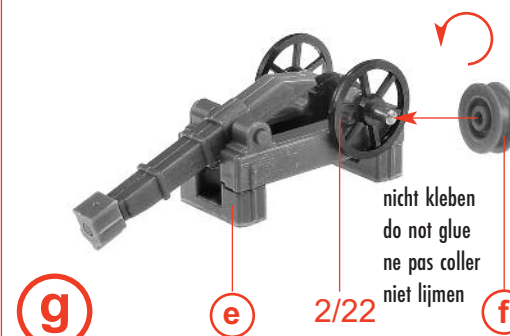

**g**

**e**

2/22

**f**

nicht kleben  
 do not glue  
 ne pas coller  
 niet lijmen

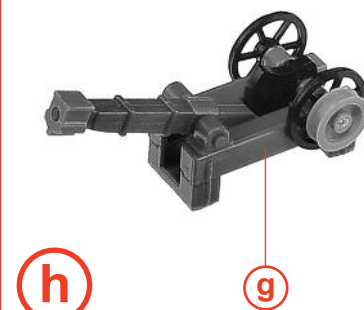

**h**

**g**

**8** Bevor die Maschinen fixiert werden, müssen die Riemenräder auf der Welle und die Riemenräder auf den Maschinen in einer Flucht stehen.

Die Maschinen in den vorgegebenen Feldern positionieren und mit wenig Klebstoff fixieren, dass der Riemen nur leicht gespannt ist. Probelauf durchführen (ca. 24 h). Falls die Riemen von den Rädern wandern, ist die Maschinenposition und ggf. die Position der Riemenräder auf der Welle zu verändern.

Verändern der Maschinenposition: der Klebstoff kann mit einem Tropfen Verdünnung angelöst werden, so dass die Maschinen verschoben werden können.

Before fixing the machines, the belt wheels on the axle and the belt wheels on the machines must be in alignment with each other.

Position the machines in the spaces provided and fix them with very little glue so as to ensure only slight tension for the belt.

Carry out a test run (approx. 24 h). If the belts shift on the wheels, modify the position of the machines or, if necessary, the position of the belt wheels on the axle.

To modify the machines' position: the glue may slightly be dissolved using one drop of solvent so as to be able to move the machines.

Avant de fixer les machines, les roues à courroie de l'arbre et les roues à courroie des machines doivent être alignées.

Positionner les machines dans l'espace prévu à cet effet et les fixer avec très peu de colle de façon que la courroie présente seulement une faible tension.

Effectuer un essai de fonctionnement (env. 24 h).

Si les courroies se déplacent sur les roues, modifier la position des machines et, si nécessaire, modifier la position des roues à courroie sur l'arbre.

Modification de la position des machines : on peut légèrement dissoudre la colle avec une goutte de diluant de façon à pouvoir déplacer les machines.

Voordat de machine wordt gefixeerd moeten de riemwielen op de as en de riemwielen op de machines in dezelfde stand staan.

De machines op de voorgeschreven plaats positioneren en met weinig lijm vastzetten zodat de riemen slechts licht gespannen zijn.

Proefdraaien (ca. 24 h). Als de riemen van de wielen lopen de positie van de machine en eventueel de positie van de riemwielen op de as veranderen.

Veranderen van de machinepositie: de lijm kan met een druppeltje verdunmiddel opgelost worden waarna de machine verschoven kan worden.

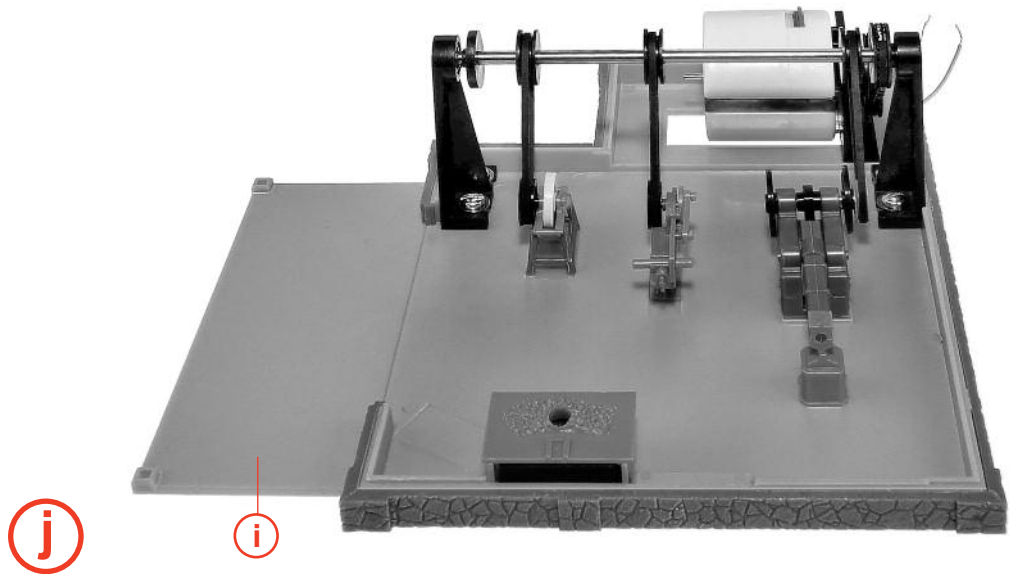
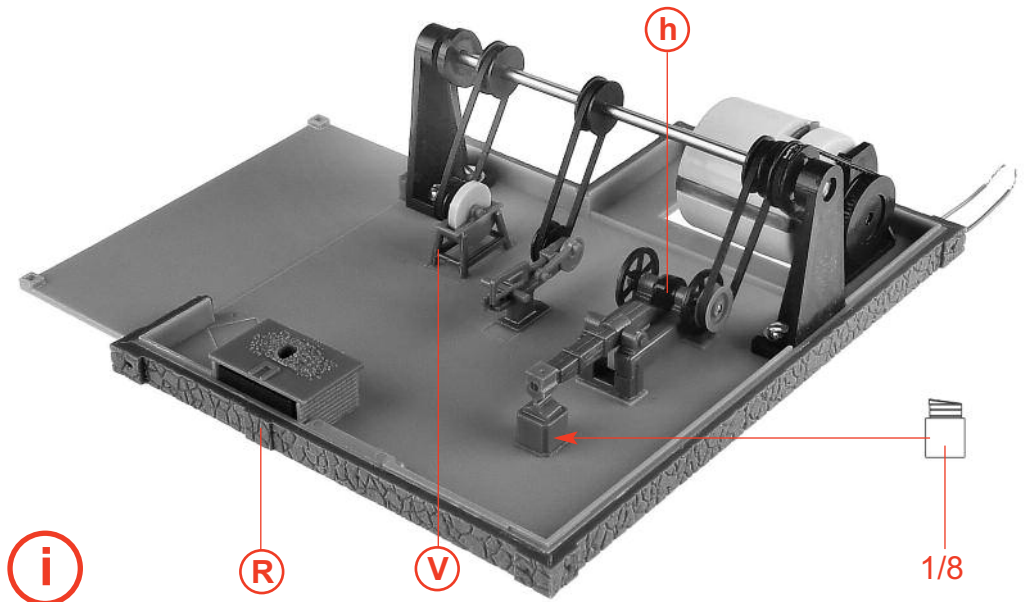



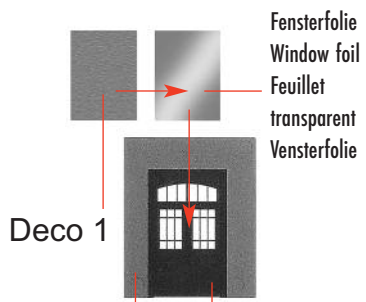

Deco 1

**k**

6/2 12/4

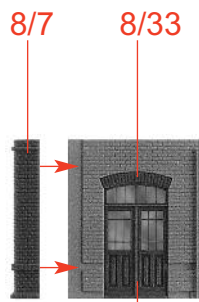

**l**

**k**

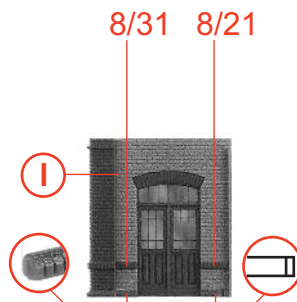

**m**

8/11 8/12

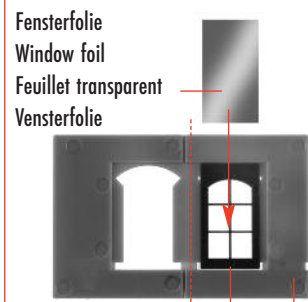

**n**

9/6 6/3

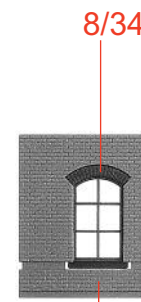

**o**

**n**

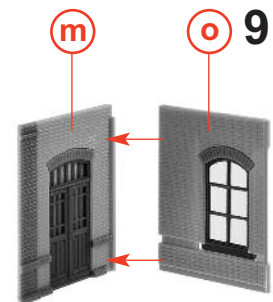

**p**

**9**

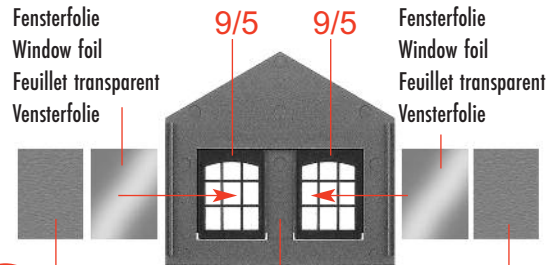

**q**

Deco 2

6/1

Deco 2

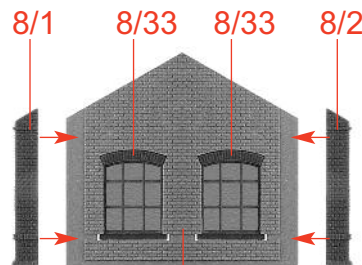

**r**

**q**

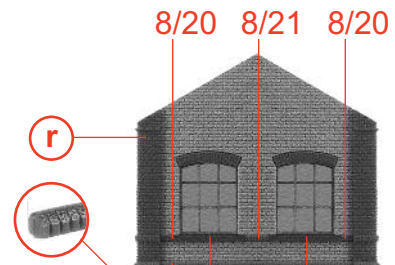

**s**

8/10 11/7

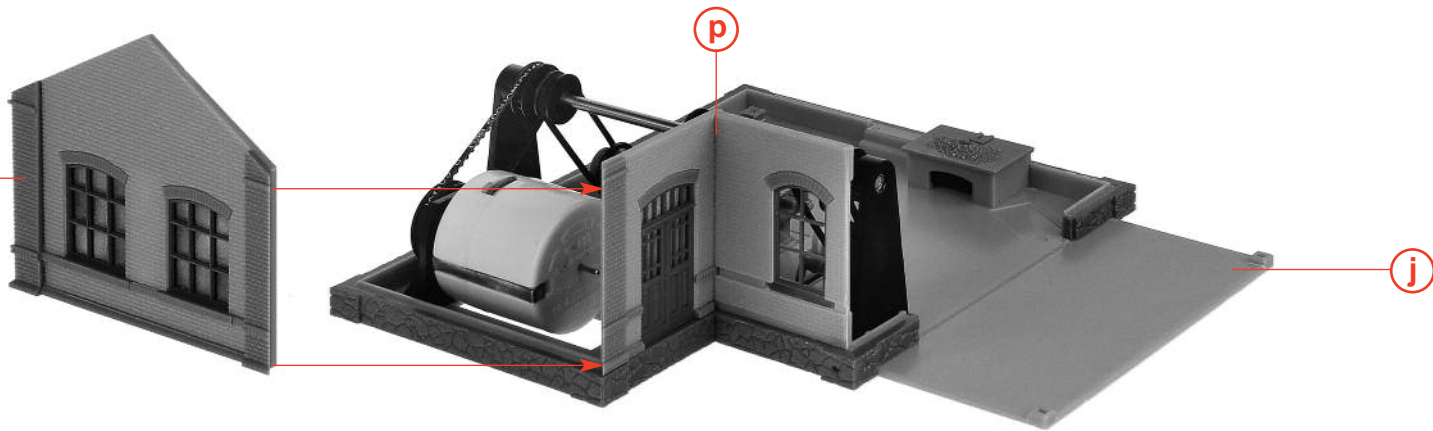

**s**

**t**

**p**

**j**

10

Papiermaske  
 Papermask  
 Masque  
 Masker **M2**  
 Mit Alleskleber kleben  
 Use all-purpose glue  
 Utiliser de la colle universelle  
 Met een universele lijm lijmen

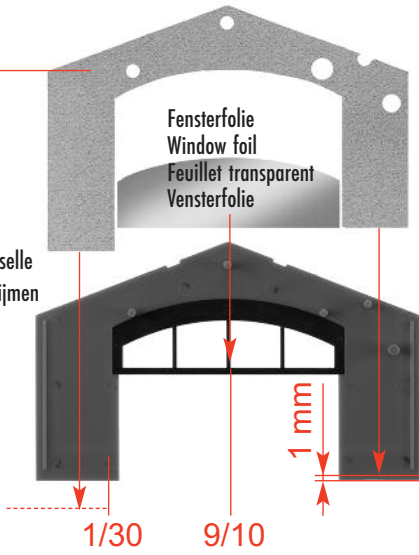

u

8/5

8/44

8/6

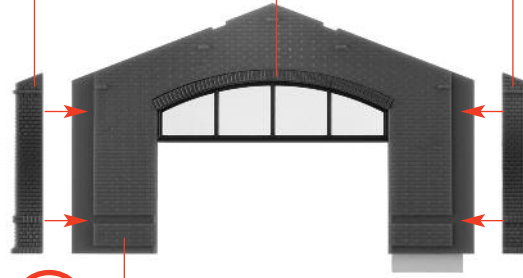

v u

8/27

v

8/27

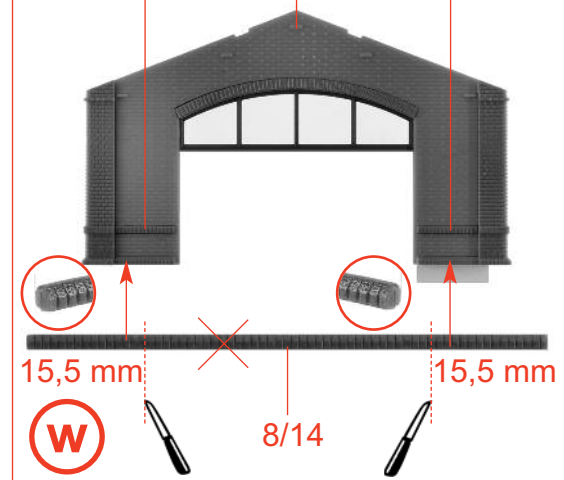

w

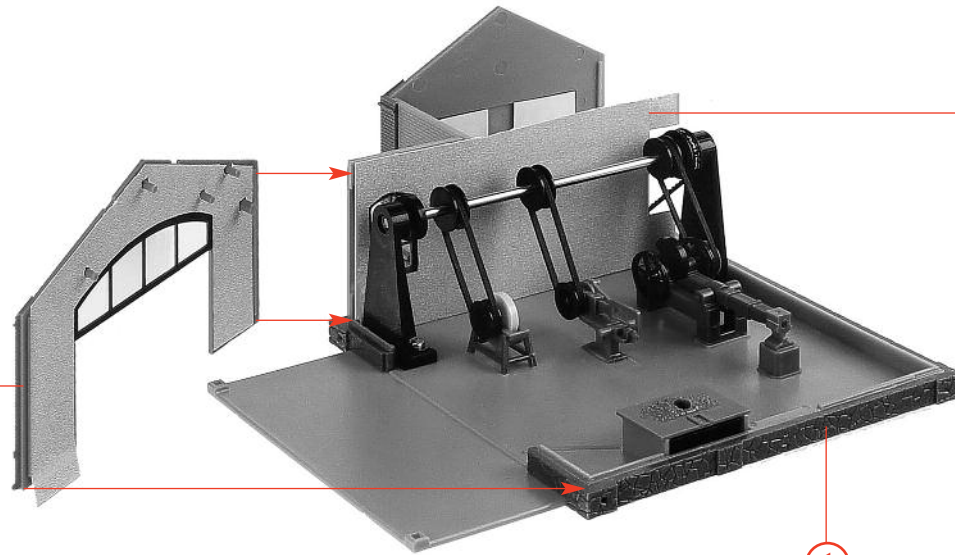

Papiermaske  
 Papermask  
 Masque  
 Masker **M3**

w

x

t

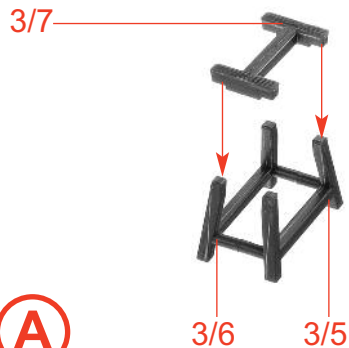

**A**



**B**

**A**

**E** nicht kleben  
do not glue  
ne pas coller  
niet lijmen

2/10

Sekundenkleber verwenden.  
Use instant modelling cement.  
Utilisez la colle rapide.  
Gebruik secondenlijm.

nicht kleben  
do not glue  
ne pas coller  
niet lijmen

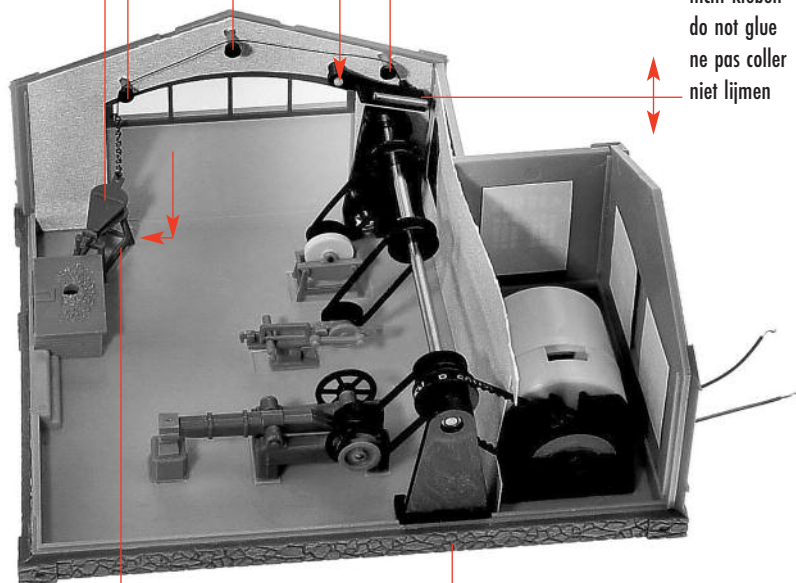

**F**

**B**

**X**

160 mm

Faden verknot und den Knoten mit Sekundenkleber fixieren!

Knot the thread and fix the thread with instant cement!

Nouer le fil et renforcer le noeud avec une goutte de colle rapide!

Garen vastknopen en de knoop met secondenlijm fixeren!

**Inhalt** Tüte 2  
**Contents** bag 2  
**Contenu** sachet 2  
**Inhoud** zakje 2

**Inhalt** Tüte 1  
**Contents** bag 1  
**Contenu** sachet 1  
**Inhoud** zakje 1

Sekundenkleber verwenden.  
Use instant modelling cement.  
Utilisez la colle rapide.  
Gebruik secondenlijm.

**Inhalt** Tüte 1  
**Contents** bag 1  
**Contenu** sachet 1  
**Inhoud** zakje 1



**D**

2/20

**C**

30 mm

3/11

115 mm

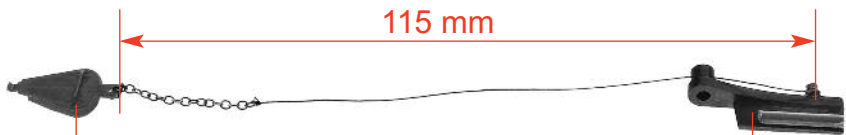

**E**

**C**

**D**

12

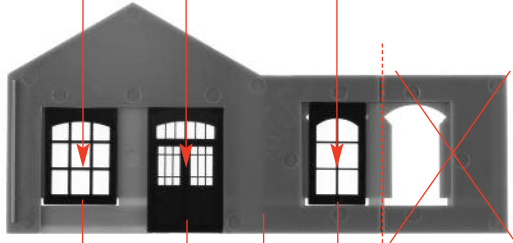
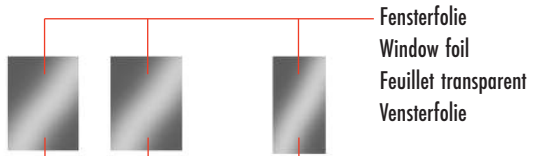

G

9/5 12/4 6/5 9/6



8/34 8/8 8/33 8/33 8/2

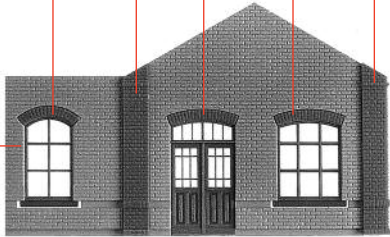

G

H

8/22 8/30 8/20

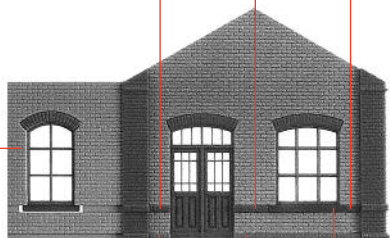

H

I



8/17 8/18 11/7

8/5

Papiermaske  
Papermask  
Masque  
Masker **M4**

Papiermaske  
Papermask  
Masque  
Masker **M5**

I

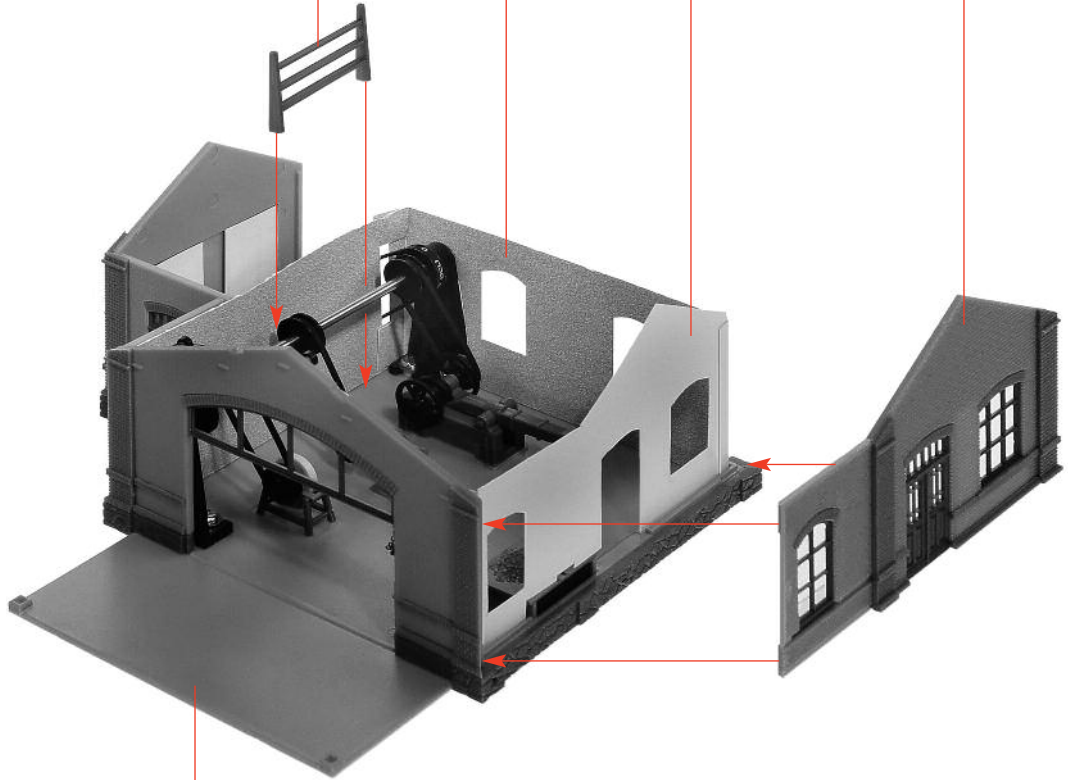

J

F

Fensterfolie  
Window foil  
Feuillet transparent  
Vensterfolie



Deco 3

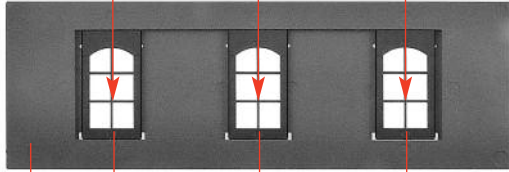

6/6 9/6 9/6 9/6

K



N

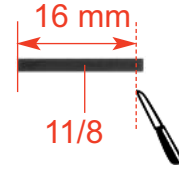

O

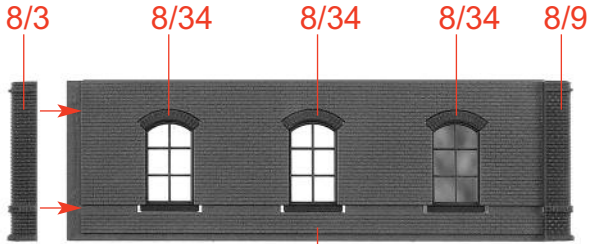

L

K

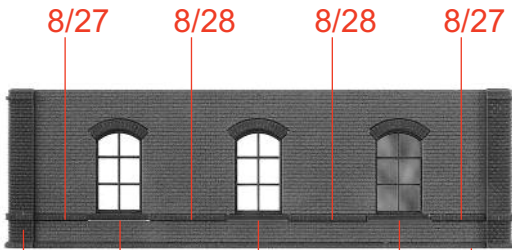

M

L 11/8 11/8 11/8 8/15

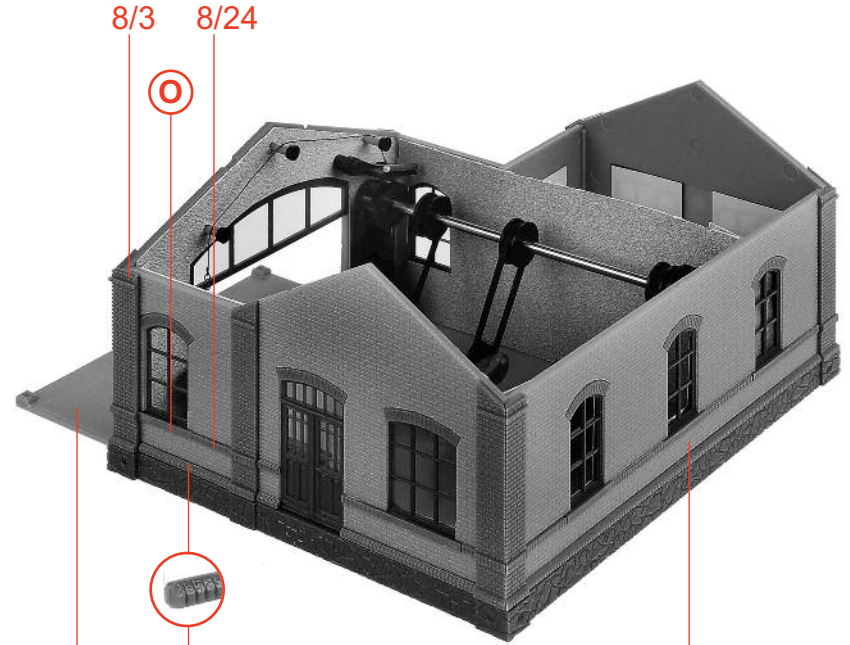

O

N

P

J

M

14

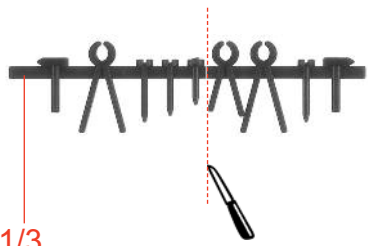

Q

1/3

R

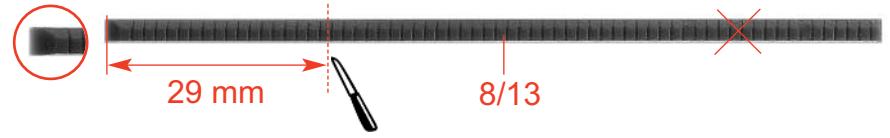

29 mm

8/13

S

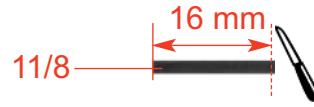

11/8

16 mm

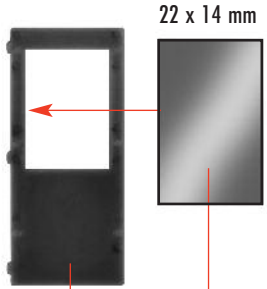

22 x 14 mm

T

4/46

Fensterfolie  
Window foil  
Feuillet transparent  
Vensterfolie



22 x 14 mm

U

4/47

Fensterfolie  
Window foil  
Feuillet transparent  
Vensterfolie

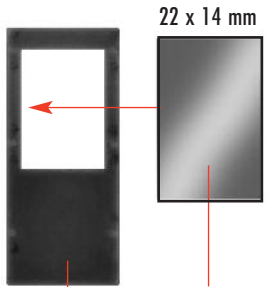

22 x 14 mm

V

4/45

Fensterfolie  
Window foil  
Feuillet transparent  
Vensterfolie

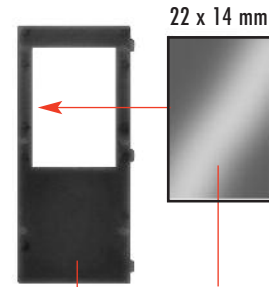

22 x 14 mm

W

4/44

Fensterfolie  
Window foil  
Feuillet transparent  
Vensterfolie

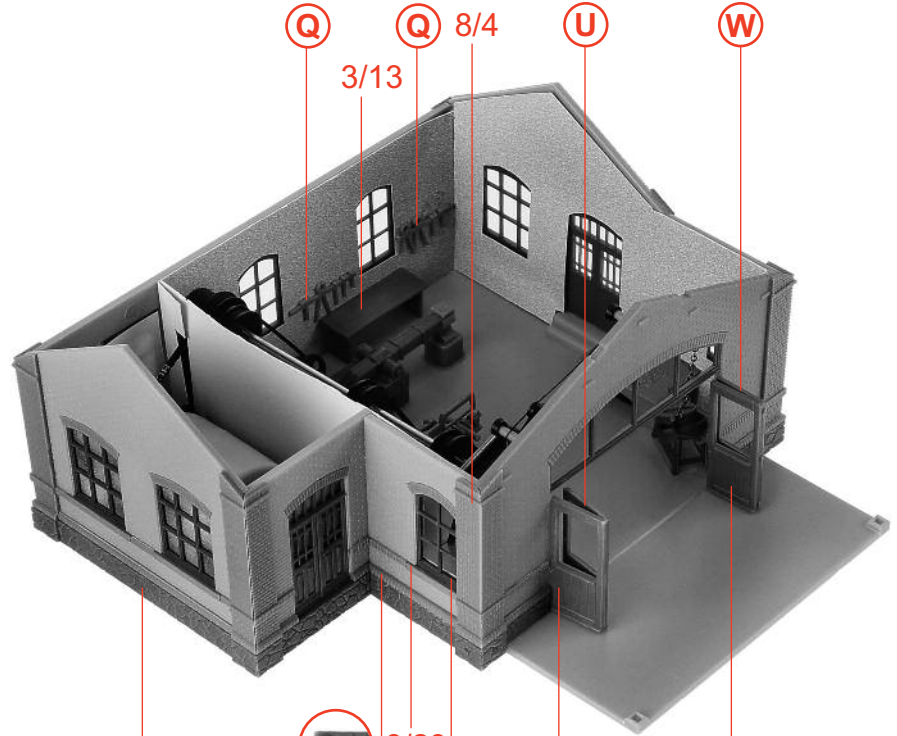

Q

Q

8/4

U

W

3/13

X

P

8/23

R

S

T

V

1/34 1/36

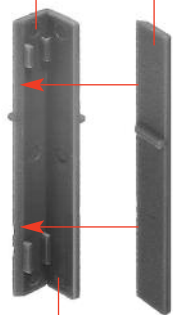

1/35

**a**

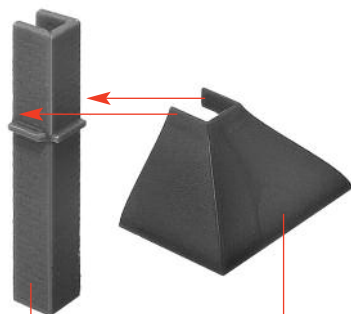

**a**

1/2

**b**

8/6

8/4

8/9

1/11

**c**

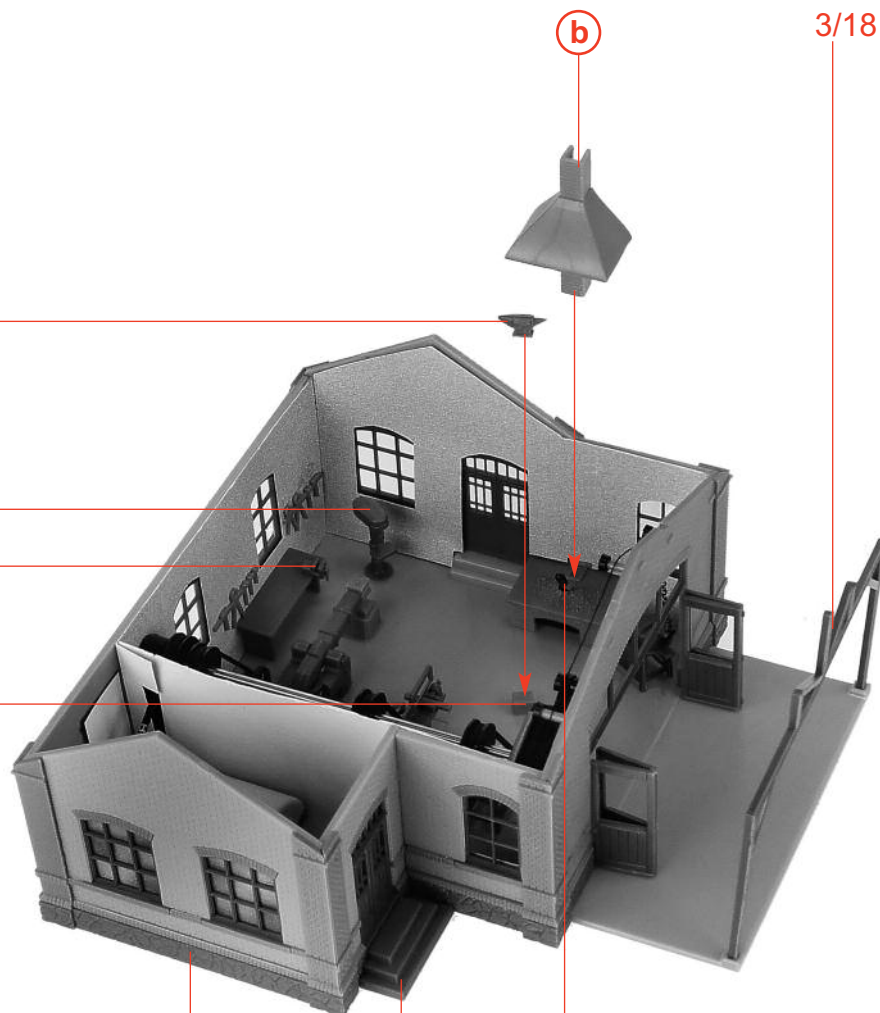

3/18 **15**

**Y**

2/9

Micro-Kabelbirne, rot 16 V Wechselspannung  
Micro-cable bulb, red 16 V AC  
Miniampoule, rouge 16 V c. a.  
Mini draadlampje, rood 16 V wisselspanning

16

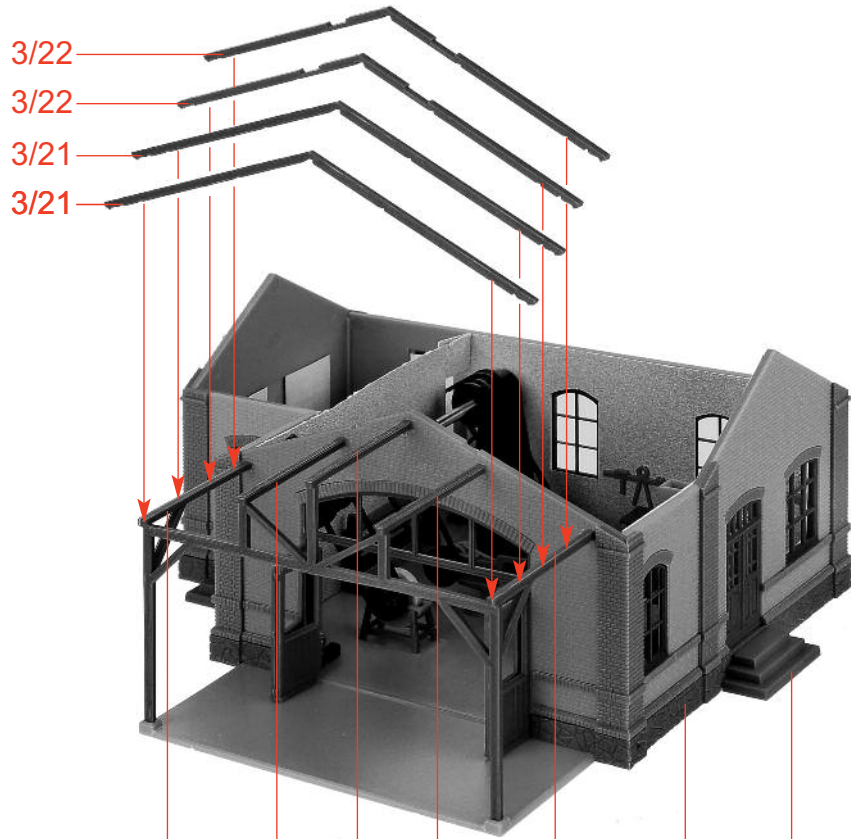

(d)

3/19

3/20

3/20

3/20

3/19

(c)

2/9

(e)

10/20



(f)

10/22

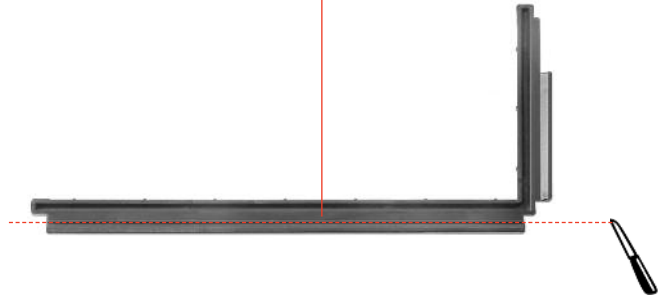



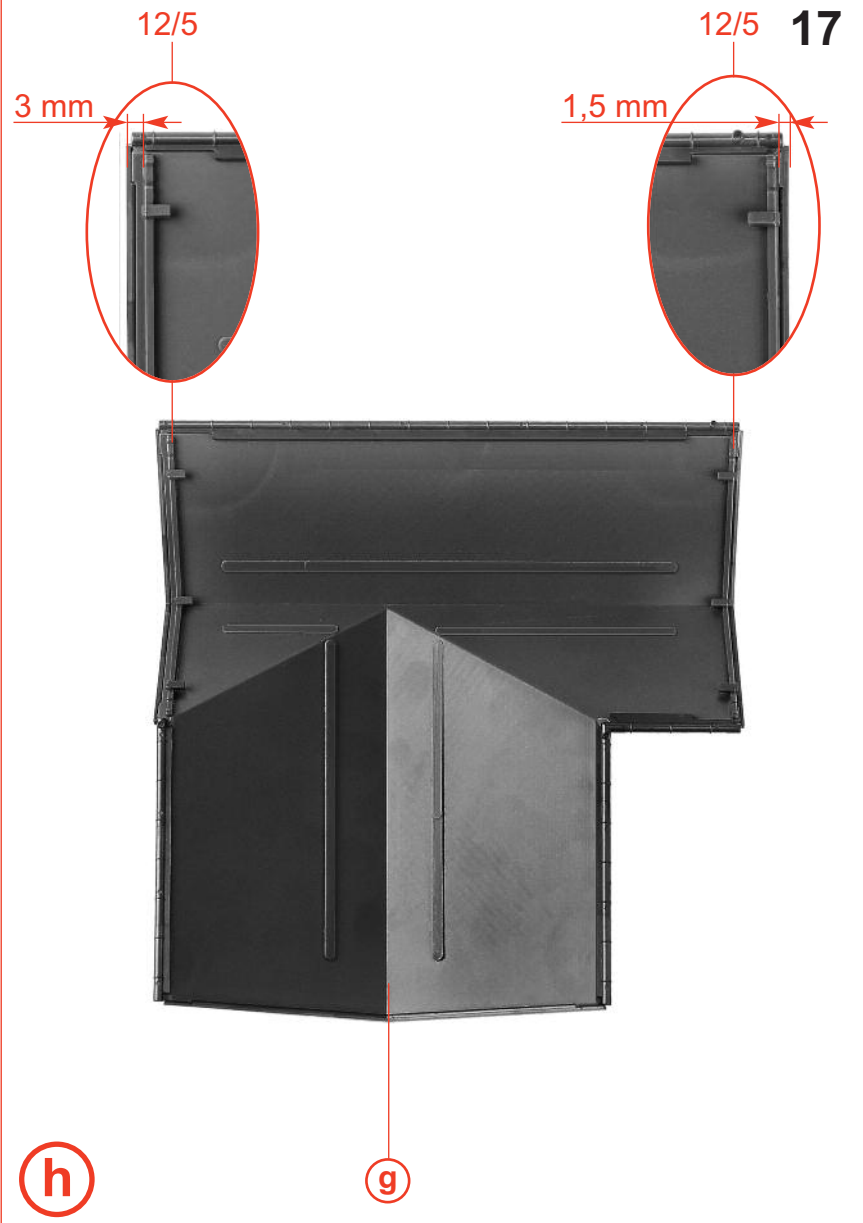
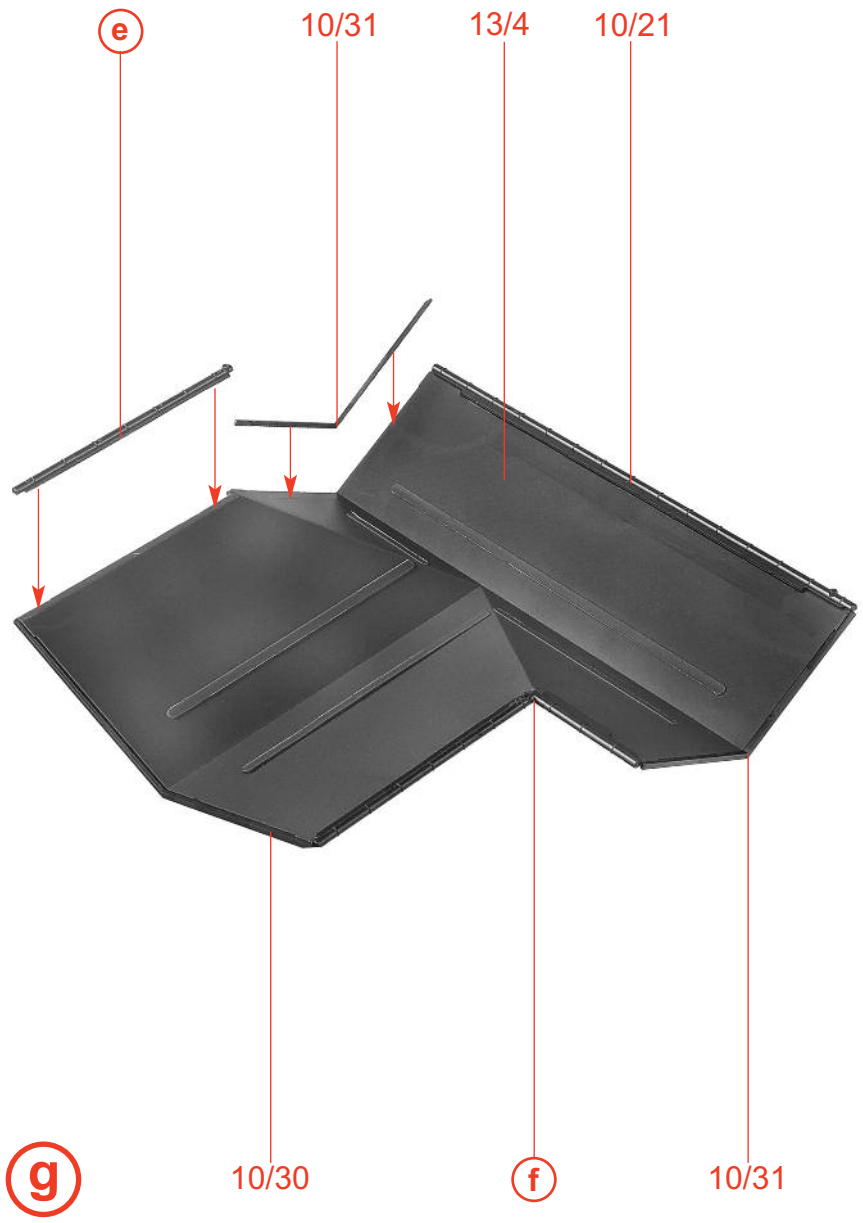

18

nicht kleben  
do not glue  
ne pas coller  
niet lijmen

h

Art.-Nr. 180653, 16 V Wechselspannung  
16 V AC  
16 V c. a.  
16 V wisselspanning

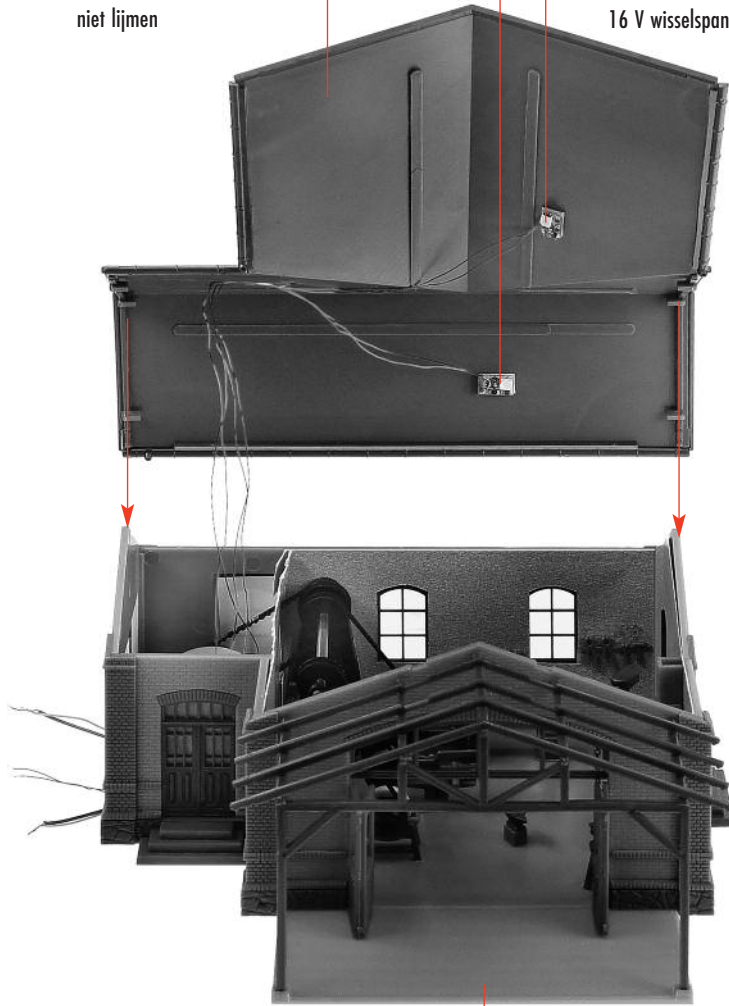

i

d

12/19 12/20

12/17

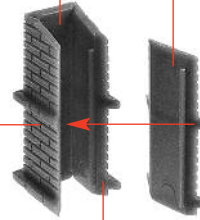

j 2 x 12/18

10/33

10/34

j

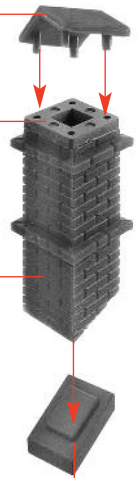

k 2 x

10/32

10/8 10/8

k

l

10/27

i

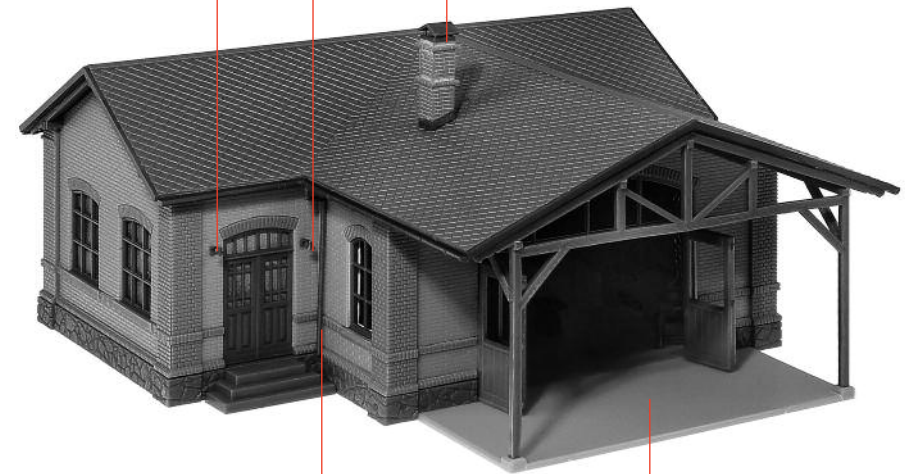

M1:1

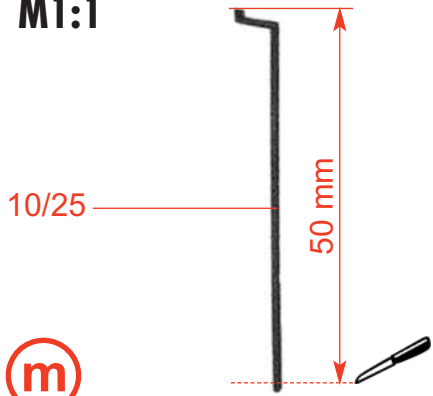

(m)

M1:1

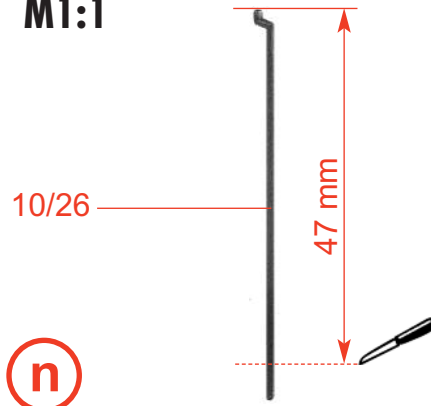

(n)

3/14

3/15

3/16

19

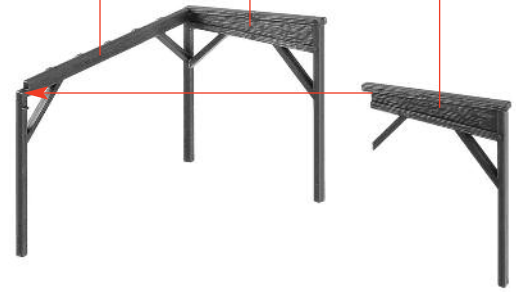

(p)

(k) 10/8

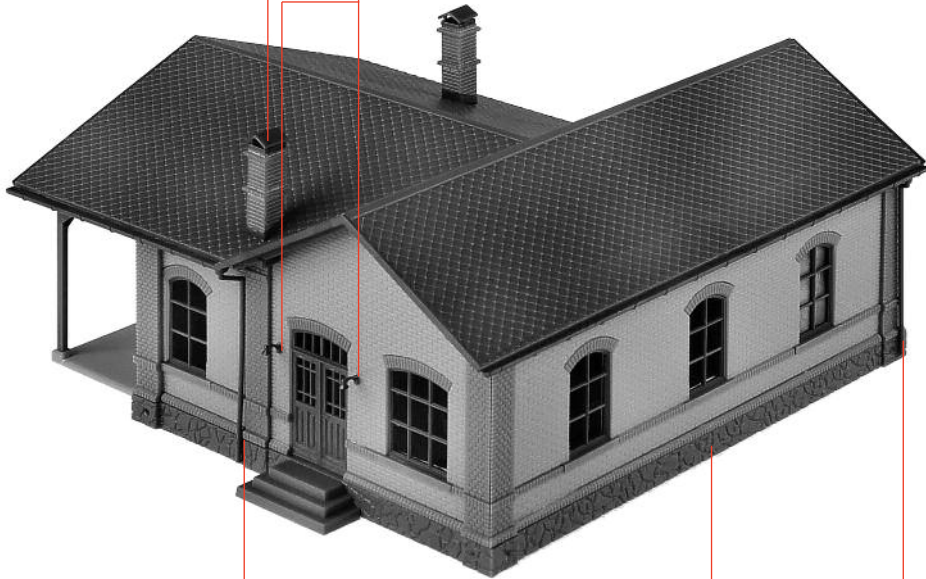

(o)

(m)

(l)

(n)

8/1

3/17

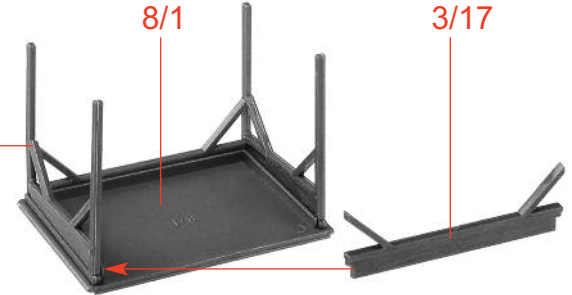

(q)



(r)

(q)

20

05-11

05-14



nicht kleben  
do not glue  
ne pas coller  
niet lijmen

05-13

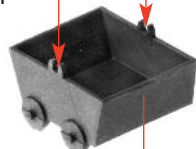

**s** 2 x 05-12

**t** 2 x 05-15

**r**

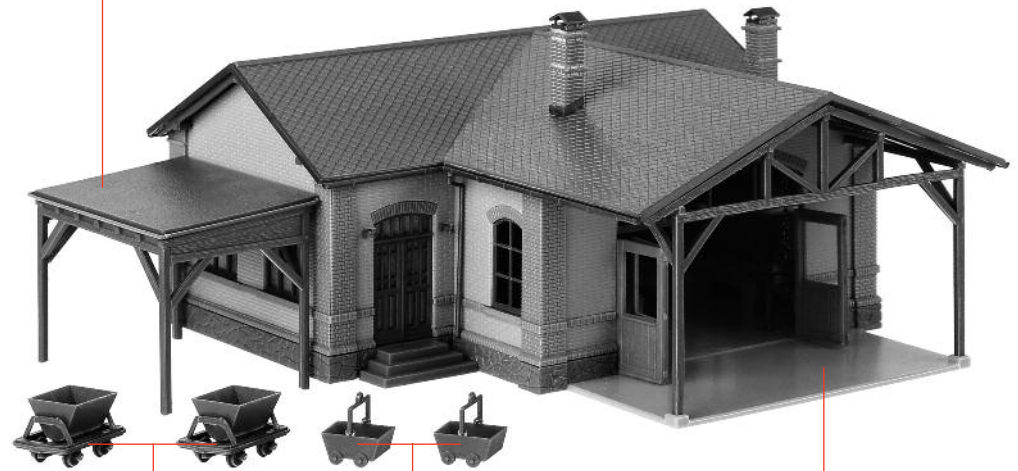

**u**

**s**

**t**

**o**

Deco 4

Schlosserei Disch

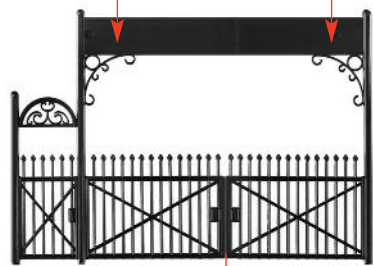

**v**

01-12

01-11

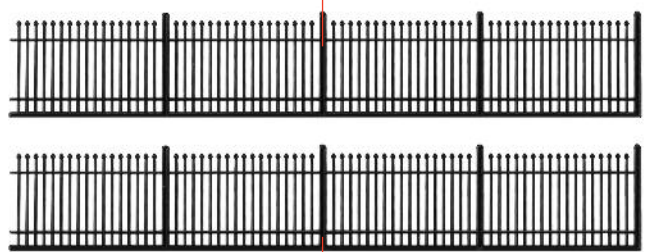

**w**

01-11



**v**