

Montageanleitung H0 E-Lockschuppen mit Türschließvorrichtung, zweiständig

Mounting instruction H0 E-Loce shed with door lock mechanism, double track

(DE)

Bitte legen Sie die Einzelteile nach Buchstabengruppen zusammen und beginnen Sie dann entsprechend der Zeichnungen mit dem Zusammenbau.

(EN)

Arrange the individual parts by letter groups, and then begin assembling in accordance with the drawings.

1. Inhalt	1	1. Contents	1
2. Montage	2	2. Mounting	2

1. Inhalt/Contents

Dekopapier: 135557

Spr.-Nr.	Teile-Nr.	Stück	Spr.-Nr.	Teile-Nr.	Stück	Spr.-Nr.	Teile-Nr.	Stück	Spr.-Nr.	Teile-Nr.	Stück	Spr.-Nr.	Teile-Nr.	Stück	
10724	10724	1	11181	10351	4	10362	10362	14	12293	10341	1	10340	10340	1	
				10352	1					10342	1				
11000	11000	1		10353	1	11179	10360	2				10460	10460	4	
				10354	2		10361	2	10367	10367	8				
11083	11083	2										11209	11209	1	
			10355	10355	14	10363	10363	1	11176	10461	2				
11175	10343	1								11210	4	11252	11252	4	
	10344	1	10356	10356	14	10364	10364	1							
11180	10345	1	10357	10357	14	10384	10384	1	10463	10463	1	11178	15358	2	
	10346	2											15359	2	
	10347	1				10366	10366	4	11182	10464	1		15827	2	
	10348	2								10465	1		15828	2	
	10349	1													
	10350	1							10466	10466	1	57630	57626	2	
													57627	2	
									11184	10365	4		57628	2	
										10467	1		57629	2	
													Zugstange	138647	2
													Drawbar		
													Türschließfeder	138021	2
													Door closing spring		

(DE)

Wir verwenden den recyclefähigen Kunststoff Polystyrol.
Wir gratulieren Ihnen zum Erwerb dieses hochwertigen Vollmer-Bausatzes.
Die hohe Passgenauigkeit unserer Bausätze wird Ihnen viel Freude bereiten.

Diverse Kleber für die Bausätze finden Sie im Vollmer Sortiment.

Änderungen vorbehalten.
Keine Haftung für Druckfehler und Irrtümer.

(EN)

We use recyclable polystyrene.
Congratulations on your purchase of this Vollmer product.
Our high quality kits will bring you much joy.

You will find various glues for the kits in the Vollmer product range.

Subject to change without prior notice.
No liability for mistakes and printing errors.

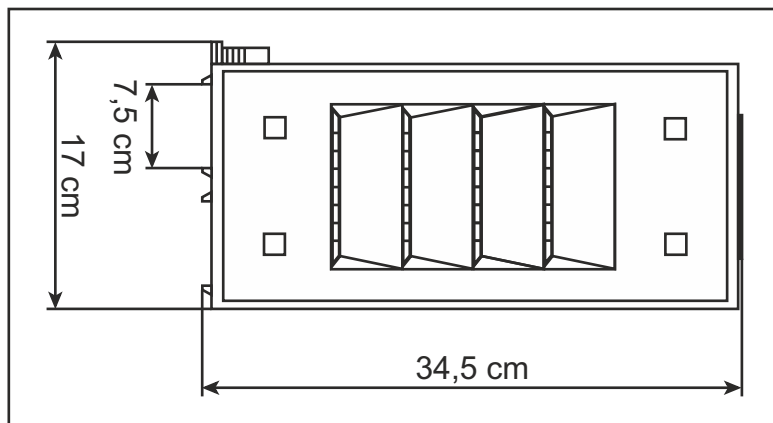

(A)

2. Montage
Mounting

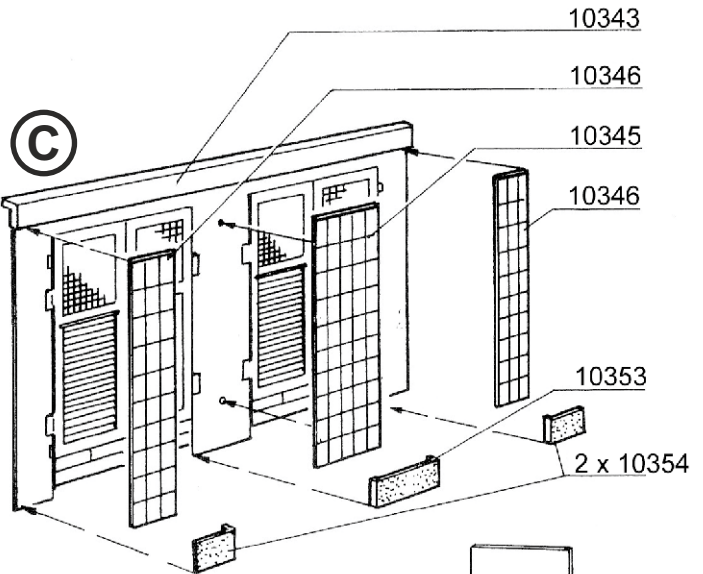
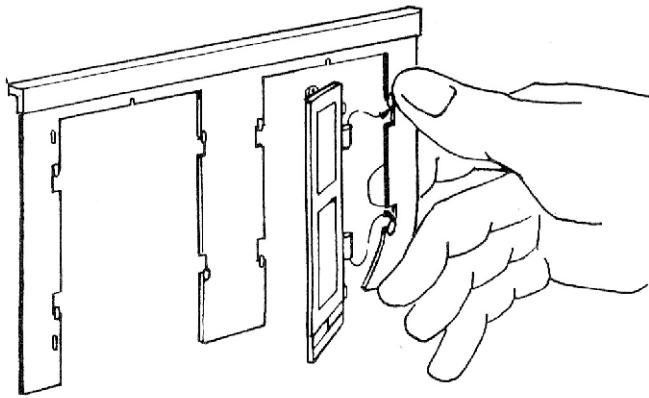
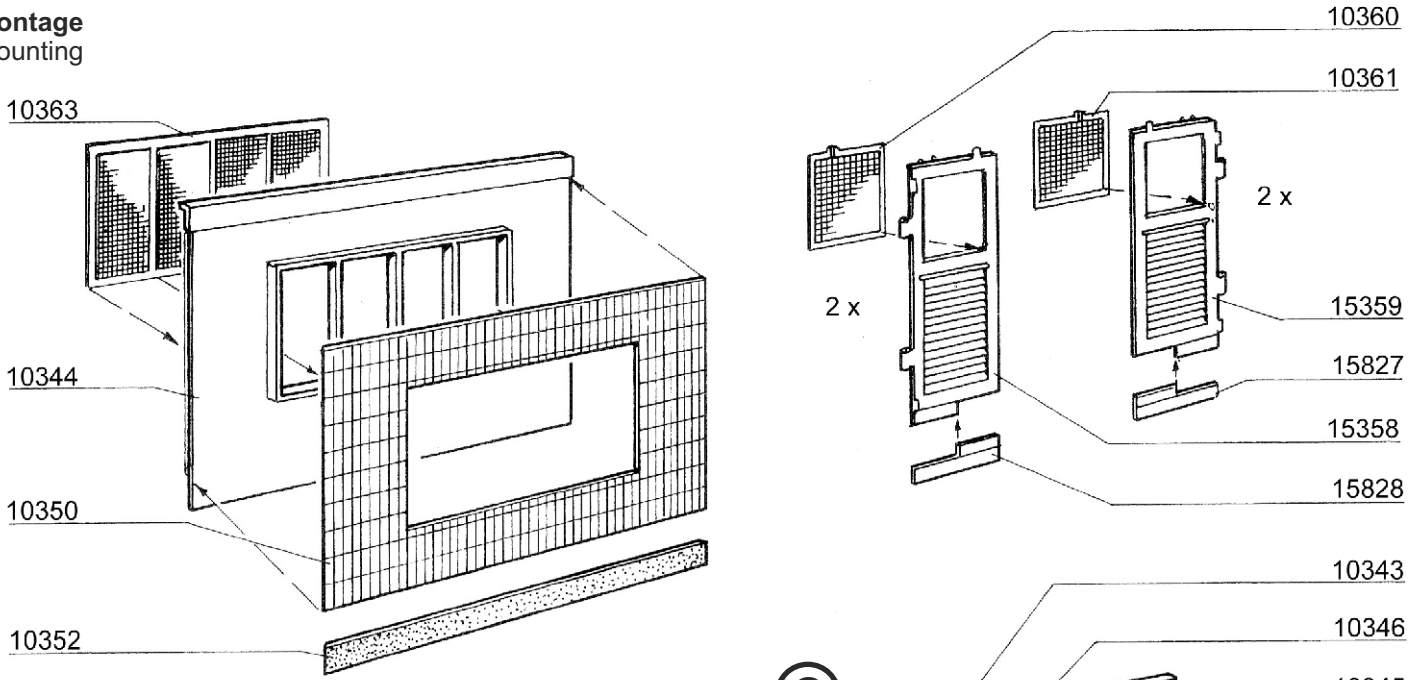

(B)

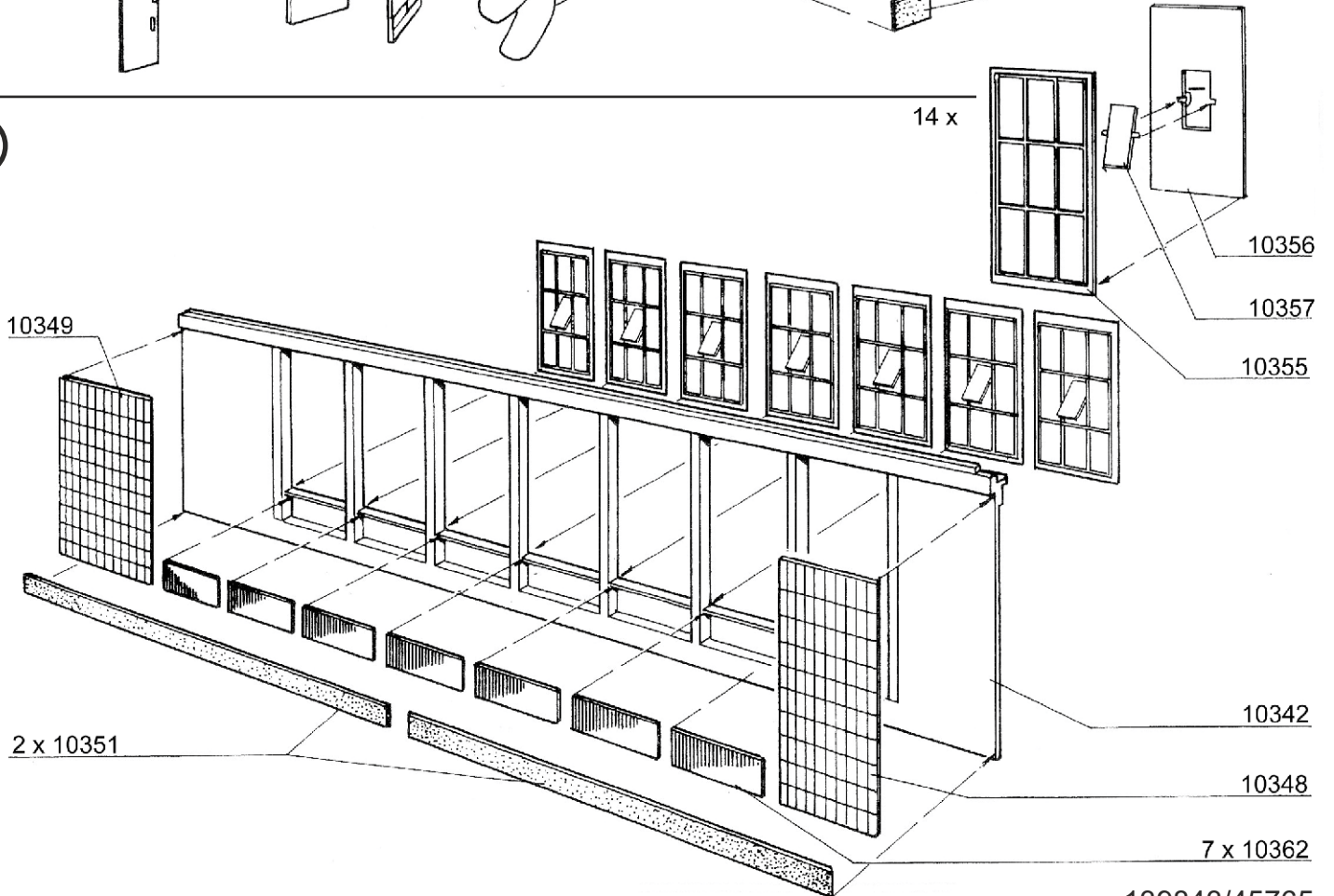

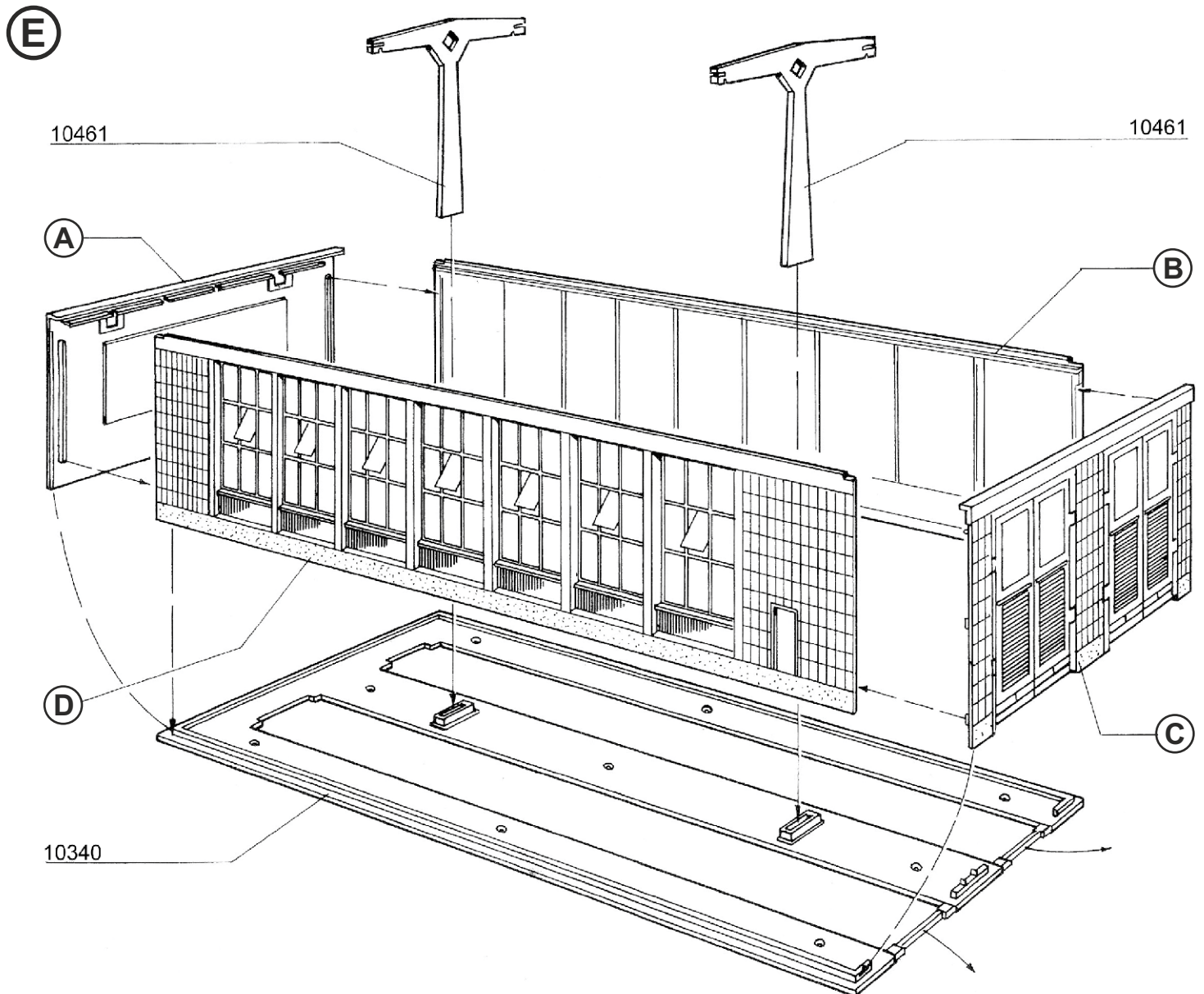
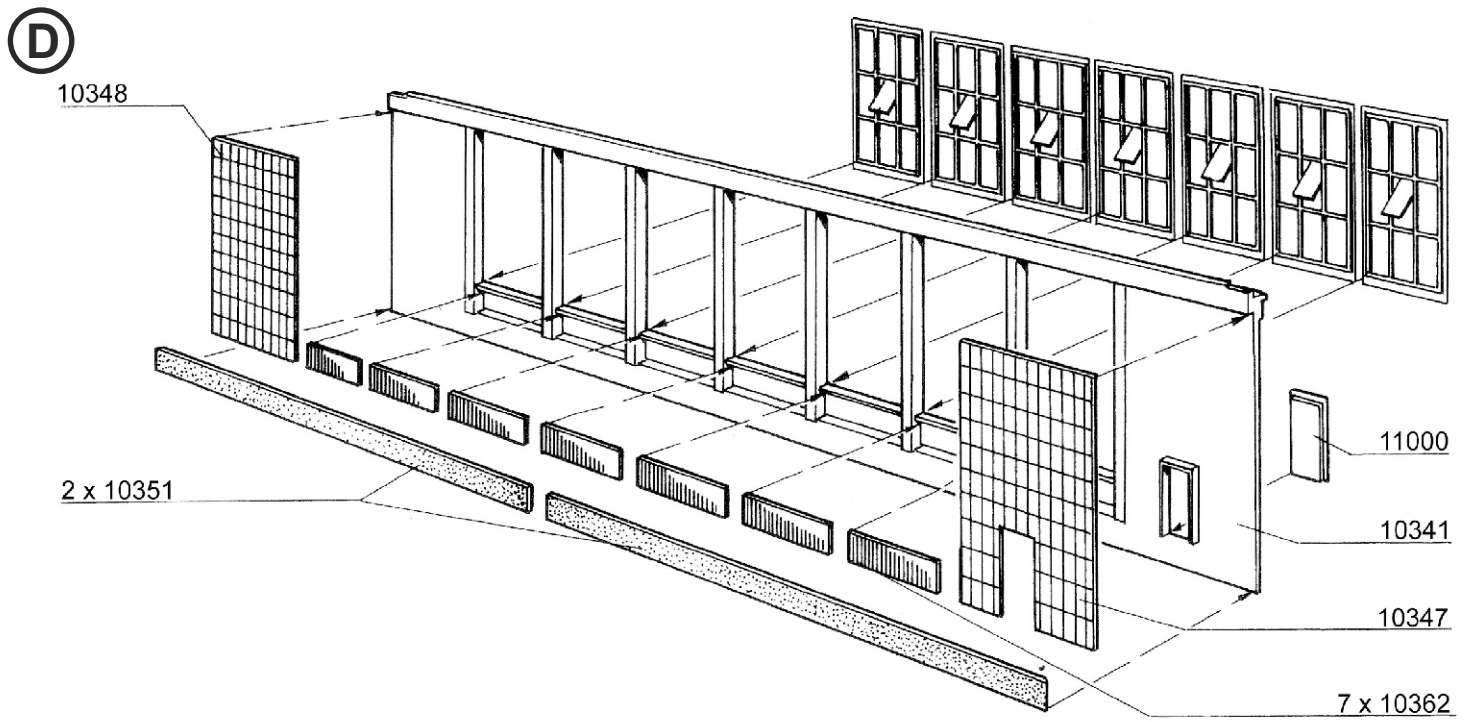

(F)

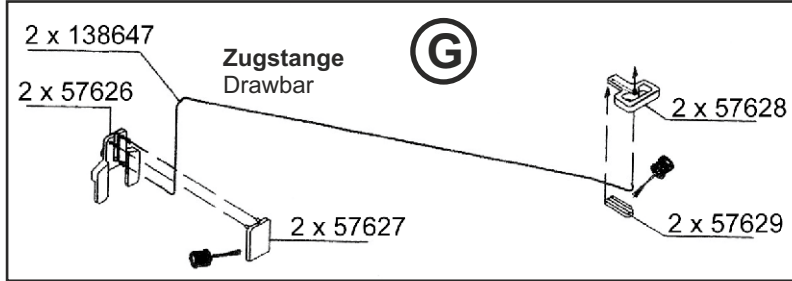

Türschließfeder
Door closing spring 138021

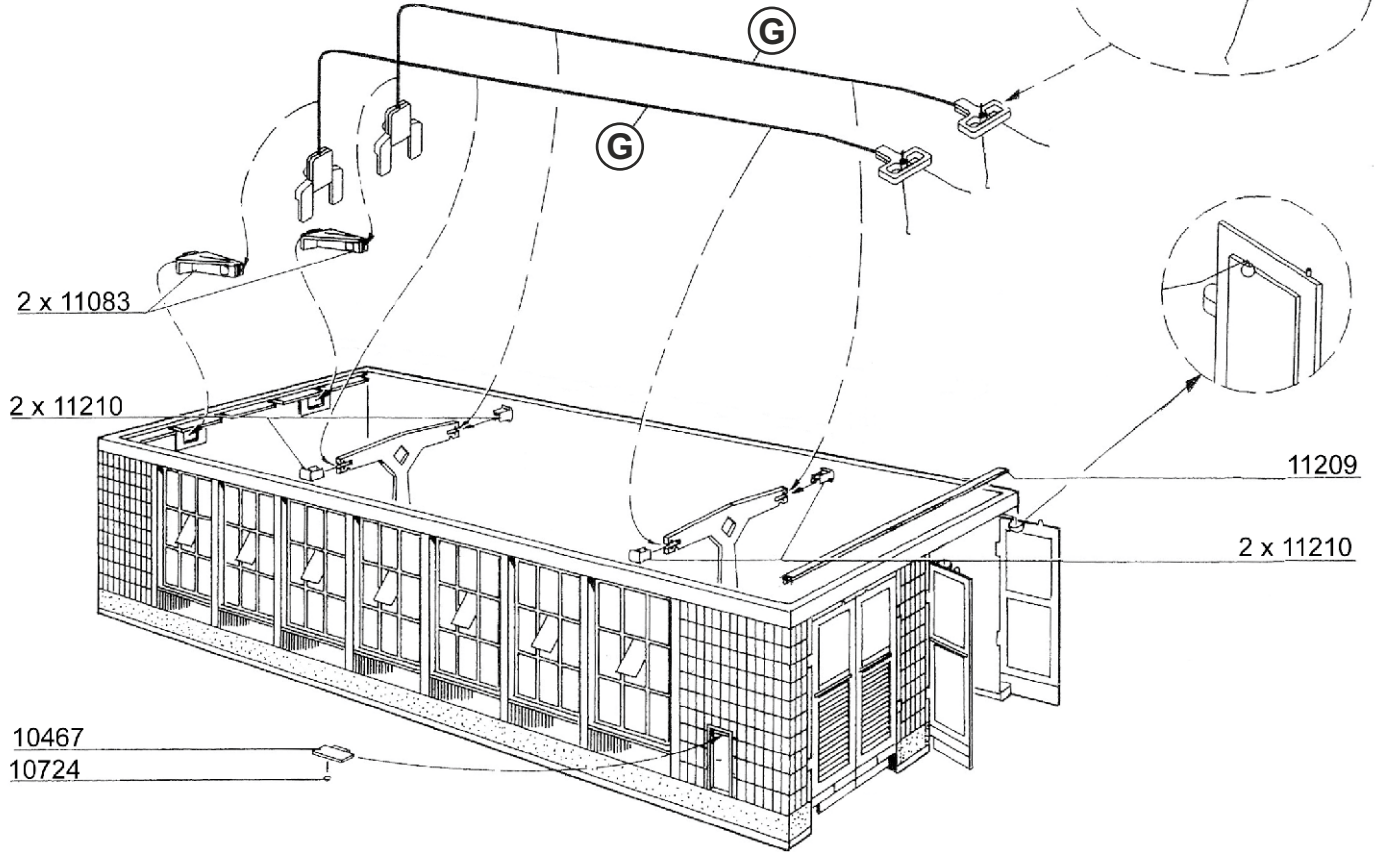
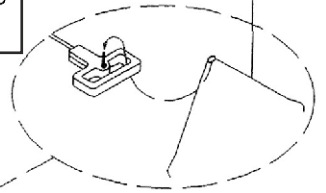

(H)

