



HO Scale Kit **ARCHED ROAD BRIDGE** 933-3196

Thanks for purchasing this Cornerstone Series® Kit. Please take a few minutes to read these instructions and study the drawings before starting construction. All parts are made of styrene, so use compatible paint and glue to finish your model.

For thousands of years, natural obstacles such as rivers and valleys prevented humans from traveling easily. In ancient times, we used natural bridges or created our own from fallen logs, piles of stones, or by twisting natural materials together. These three starting points were the foundation for the beam, arch and suspension bridges of today.

Over time, the art and science of bridge building continued to evolve. With the rise of the Roman Empire and its extensive road system, bridge building took on a new importance across Europe. During this time, engineers made significant advances including the development of the masonry arch and the use of natural cement. During medieval times, bridges were often constructed by religious orders, often incorporating shops and fortifications in their designs. By the Renaissance, advances in mathematics led to improved truss and arch designs, and a better understanding of the workings of pilings and supports. In this period, bridges were designed with more attention to how they fit the ideal of a city scene, with more atten-

tion to visual and artistic details.

While iron had been used in a very limited way since ancient times, it became available in large quantities for the first during the late 18th century. Engineers had a new and durable material with which to work, and iron bridges began to appear. With its increased load-bearing ability, iron was also adapted to the heavier bridges required by the new railroads. But iron had its limitations and by the late 19th century, steel was taking over as the material of choice, especially for railroad bridges that had to support heavier trains.

At the same time, advances in concrete and cement technology made it increasingly popular as a building material for both foundations and bridges. Engineers soon found that pouring concrete over a skeleton of iron screen, rods or bars increased the strength of the finished design and allowed for a variety of shapes and forms. On a larger scale, this “reinforced concrete” became increasingly common as a material for new bridges.

As America began shifting from horses to horsepower, a new generation of highway bridges appeared. Increasing volumes of trucks and automobiles presented problems for bridges built to carry horses and carriages in cities, as major routes became increasingly congested. And as the highway system expanded into rural areas, older wooden bridges had to be

replaced. During the 1920s and 30s, many of these older bridges were replaced as state and federal projects. These combined ancient ideas such as the arch with modern technology to produce durable, attractive structures. Many of these bridges remained in use for decades, until outdated by newer safety standards, increasing volumes of traffic and old age. On less traveled routes, some survive today.

ON YOUR LAYOUT

Perfect for any highway from the 1920s to the present, this single arched, concrete bridge is typical of those built all over America. Handling traffic above and below, bridges like this were often constructed in areas where existing intersections were creating bottlenecks and safety hazards.

Both the deck and the lower level are designed for use with any of Walthers Cornerstone Series Street Systems components, which are available to model brick, concrete or asphalt streets to fit a wide range of modeling eras. You can also set the time and place of your street scene quickly and easily with the many styles of Cornerstone Series Built-Ups Street Lamps (#933-1080 and #933-1090 series).

For additional figures, vehicle and accessories to set the scene, see your dealer, check out the latest Walthers HO Scale Model Railroad Reference book or visit our Web site at waltherscornerstone.com for more ideas.

IMPORTANT NOTE: There are various ways to build this kit. Before beginning construction, look over the possibilities and choose the one that fits your needs. Depending on the one you pick, you may need to purchase additional bridge kits and/or Cornerstone® Street System kits.

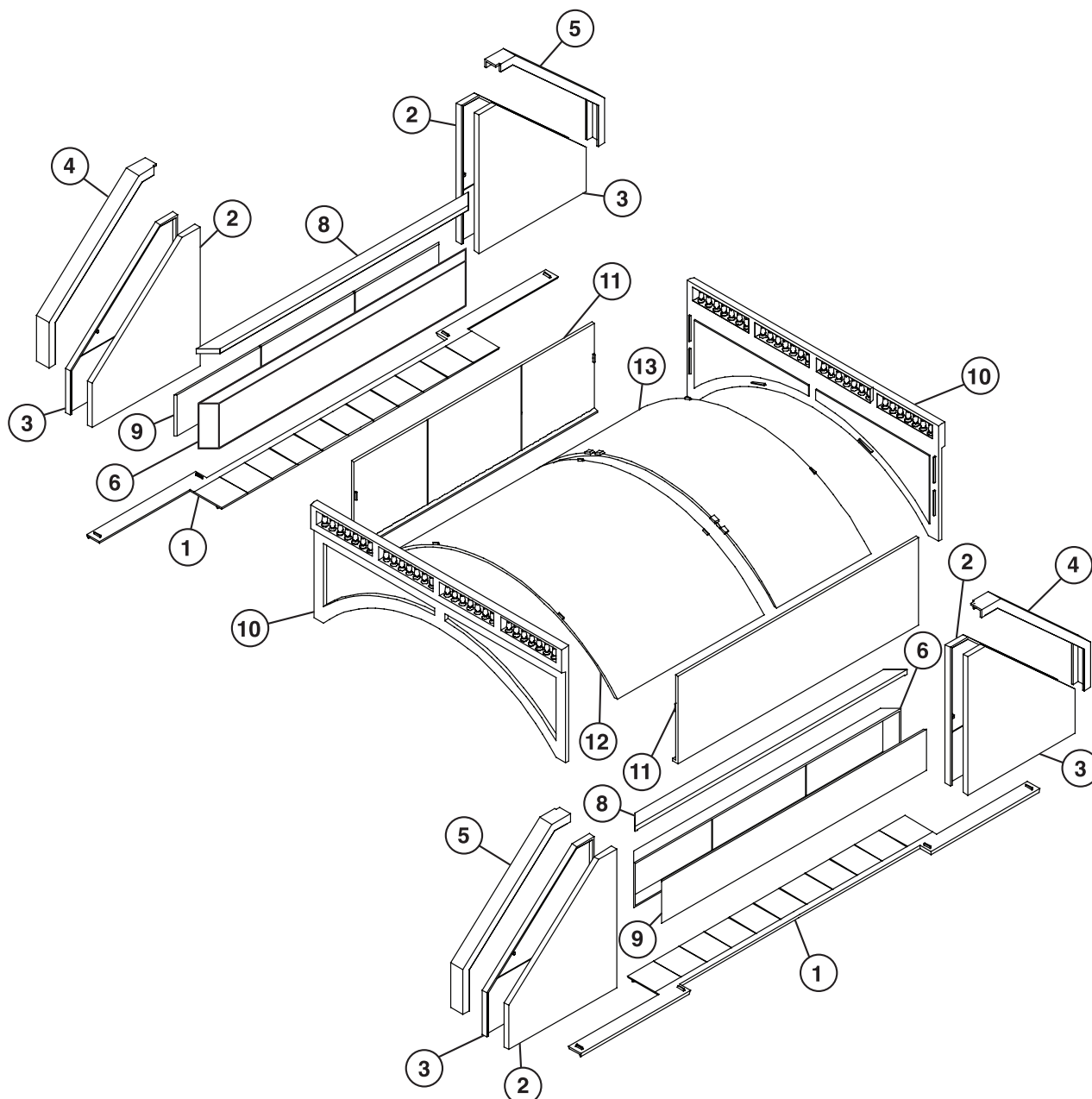

STANDARD CONSTRUCTION:

1. Glue abutment walls (2, 3) together as shown. Glue the finishing caps (4, 5) onto the walls. Note: The finishing caps have notches in one corner, and should be installed as “pairs” of left and right hand parts. Study the drawing closely for proper positioning and glue the completed wing walls to the sidewalk baseplate (1).
2. Glue the piers (6, 8, 9) together. Then glue the completed pier assemblies to the sidewalk base (1), making sure it is centered.
3. Glue the inner walls (11) to the sides (10) as illustrated. Glue arch sections (12, 13) together, and then to the sides (10) and ends (11) of the bridge as shown. Walthers Street System components are used for the upper roadway. You will need to construct 4 full panels, including the sidewalks, curbs, road surface, and splice plates as shown in the Street System instructions. (Available versions include Concrete 933-3128, Asphalt 933-3194 or Brick 933-3139. All three will work with this kit but are not included). After the completed panels have had time to dry, glue the roadway to the completed arch support. Glue the completed arch/roadway assembly to the piers built in step 2 as shown.

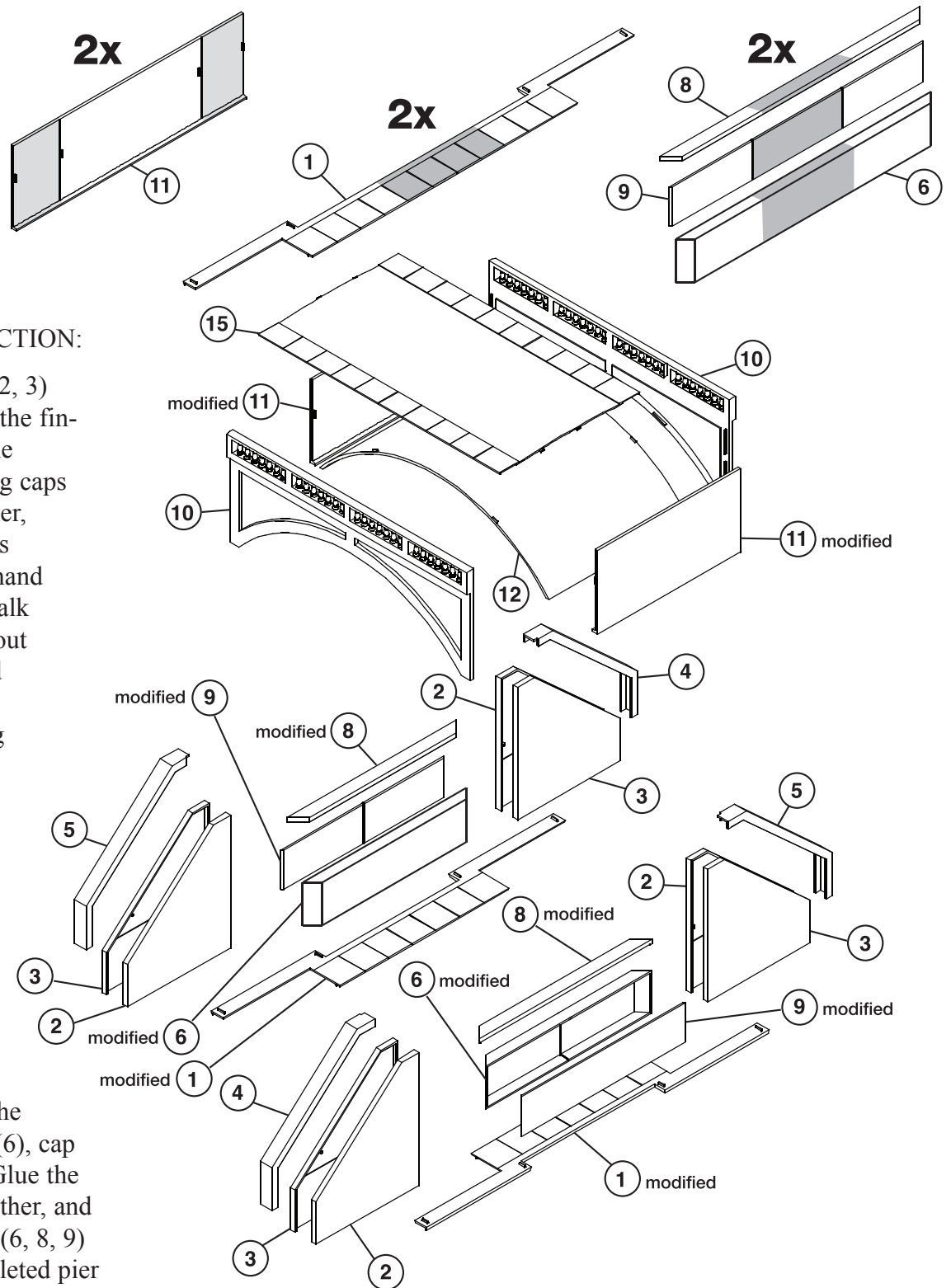

MODIFIED CONSTRUCTION:

1. Glue abutment walls (2, 3) together as shown. Glue the finishing caps (4, 5) onto the walls. Note: The finishing caps have notches in one corner, and should be installed as "pairs" of left and right hand parts. Shorten the sidewalk baseplate (1) by cutting out and removing the shaded area between the scribed lines. Glue the remaining sections back together. Finish up by gluing the wing abutments to the shortened bases (1) as shown.

2. Remove and discard the shaded portions on pier (6), cap (8), and back plate (9). Glue the saved sections back together, and when dry, glue the piers (6, 8, 9) together. Glue the completed pier assemblies to the sidewalk base (1), making sure they are centered. Glue the inner walls (11) to the sides (10) and arch (12). Supplied roadway plate (15) can then be glued on top. Glue the completed arch/roadway assembly to the piers as shown.

MULTIPLE SPANS:

1. If you are planning on combining several kits to make a longer bridge, special central piers (1 needed per additional kit) must be built. Glue pier sides (6) back to back, and finish by adding cap (7). Cut off the shaded areas on the sidewalks (1) and glue together, side by side.
2. Follow the instructions for the style (standard or modified) of bridge you desire and glue the ends together. Glue the central pier to the modified sidewalk and glue under the glued ends as shown. Finish by gluing on the pilasters (14) to cover the joints.

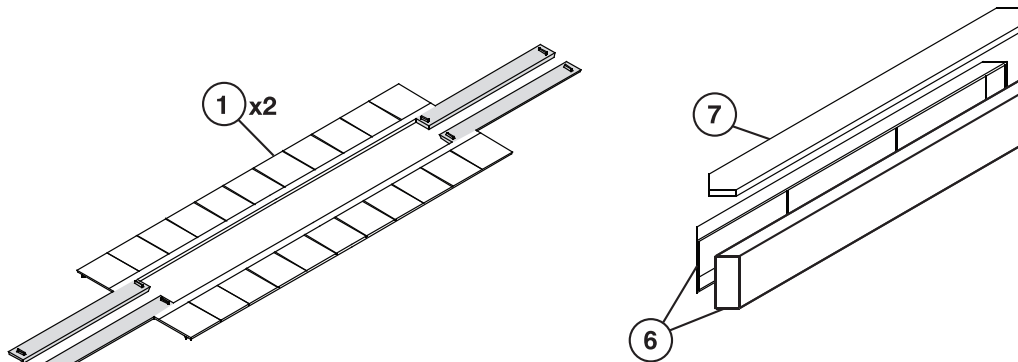

Note: If you are building the modified bridge, alter part #s 1, 6, 7 as seen on page 3, so they match.

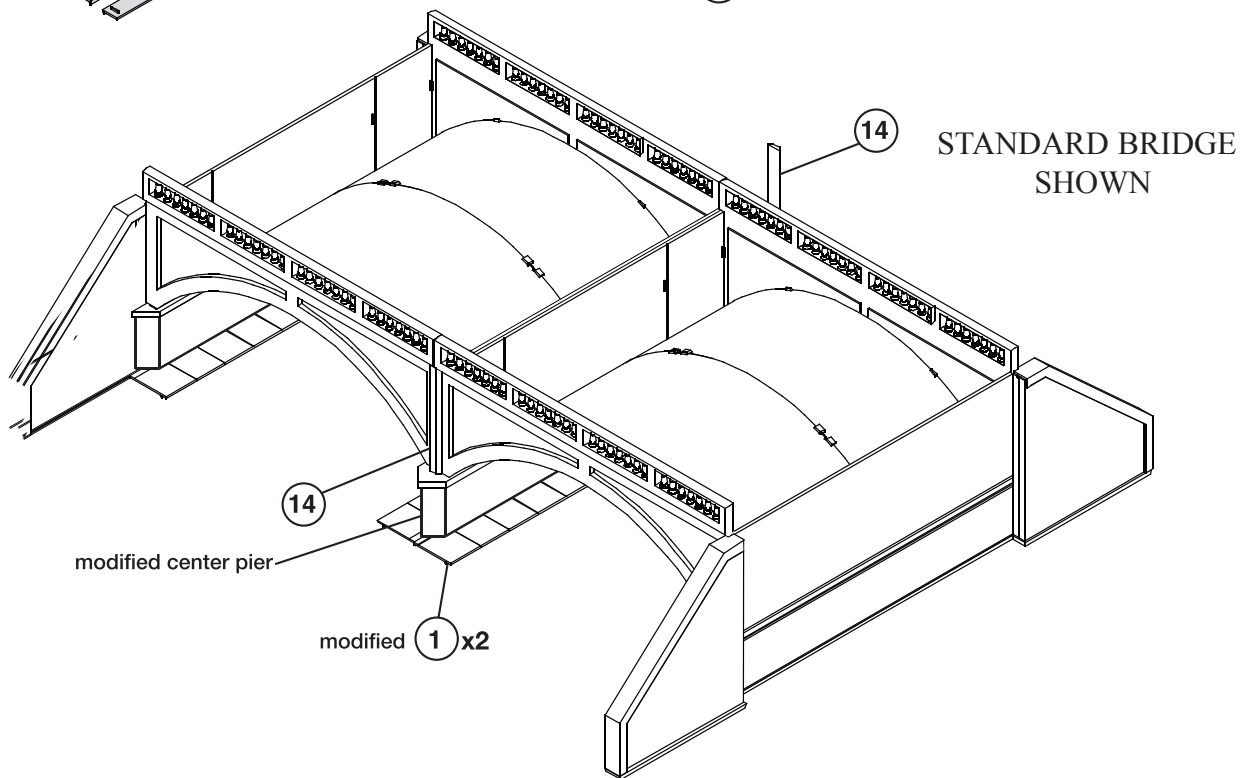

LOW LEVEL BRIDGE:

1. If you wish to have the bridge span a body or water, you can lower the structure by first, cutting off the shaded areas of the abutments (2, 3) before gluing together.
2. Then assemble the bridge without using the piers (6, 8, 9) and sidewalks (1).

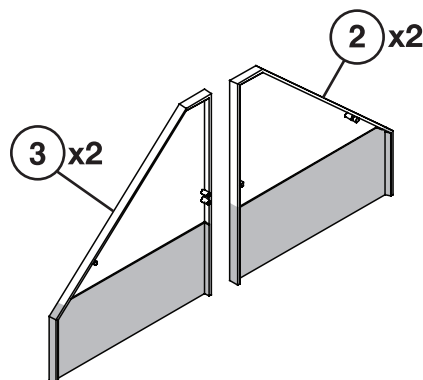

SIGNS

To mount signs, simply cut the desired image and, using a small drop of white glue on the back, glue it in place on the abutment and/or bridge.