



## HO Structure Kit GAS STORAGE TANK 933-2907

Thanks for purchasing this Cornerstone Series® kit. Please take a few minutes to read these instructions and study the drawings before starting construction. All parts are made of styrene plastic, so use compatible paint and glue to assemble and finish your model.

Long before electricity and natural gas, American homes and industries were powered by coal gas, also known as "town" or "manufactured gas," a byproduct of the coke-making process. First used in Britain in 1792, coal gas remained little more than a sideshow novelty in America until 1816, when the city of Baltimore authorized a private firm to build a generating plant and pipelines to operate gas streetlights.

Fueled by its low costs, high demand and relatively simple technology, the gas industry flourished in larger cities where it was used by residential and industrial customers for lighting, heating, cooking and to power machinery. Getting gas to customers proved troublesome however, as early pipelines and distribution systems were just not up to the job. As a result, numerous small gas plants were scattered throughout big cities, each serving a limited number of customers.

While these plants came in every shape and size, the basic operation was the same. The process began by baking soft coal at high temperatures in large, airtight ovens known as retorts. Once these were in operation, gas was always available. As long as demand remained steady, this presented few problems. But with more and bigger customers, gas works soon found themselves hard pressed to meet demand during peak periods, especially in the morning hours when factories began production. As demand rose or fell, the system couldn't be adjusted to increase or reduce production. By day, smaller customers often experienced dramatic drops in line pressure. And at night, the works was producing more gas than needed. To compensate for these extremes, gas works soon included large storage cylinders, where gas produced during off-peak hours was held in reserve and to maintain a constant pressure in the supply lines.

By the 20<sup>th</sup> century, the introduction of special high-pressure pipe and related distribution equipment saw a major shift in how the industry operated. Small plants were

soon replaced in big cities by a single facility, capable of distributing gas over long distances. This also made it possible for small towns to affordably build and maintain their own gas plants.

Major institutions such as hospitals and military bases operated their own plants, as did hundreds of large industries. The storage tanks also evolved into gigantic structures known as telescopic gasholders. These black giants towered above the surrounding area and soon became the signature structure of every gas works.

These structures were designed to expand as more gas was pumped inside. The lowest portion was filled with water almost to its top, which formed an airtight seal.

Above this were from one to four telescoping sections made of lightweight steel, known as "lifts;" the top lift was sealed with a roof. The bottom of each lift had a u-shaped rim called the "dip," while the upper edge had an n-shaped rim, called the "cup." These were also filled with water to maintain the airtight seal. As the tank was pressurized, the top section rose first, and as the cylinder filled, the cup and dip of each lift would hook together, pulling the next section upward. As pressure decreased, each lift from bottom to top would slowly drop; the cup and dip on each section would automatically disengage to allow the lift to settle. To keep the lifts aligned as they rose and fell, they rode on a series of guide rails supported by a spider web of steel trusses on the outside of the tank.

But the handwriting was on the wall for the coal gas industry. Increasing demand for petroleum products raised the cost of oils used in producing gas. Advances in distribution and generating systems made it possible to supply electricity over wider areas. Huge sources of natural gas were discovered, which virtually eliminated the need for coal gas plants in major markets. And mounting pressure from public and government to control the discharge of toxic waste products soon brought an end to the local gas works. The big gasholders, once seen as a sign of progress, were now looked upon as a blemish on a city's skyline. And as the tanks and their framework were made of steel, they were easily demolished and reclaimed as scrap. The last commercial gas works ended production in 1966,

but private industrial production continued into the 1990s.

### ON YOUR LAYOUT

As one of the tallest buildings in most cities and towns, your new Gas Storage Tank will be the most visible point of any gas works and is equally at home with many large industries.

In many operations, gas was the primary product, while coke and other materials were sold to other users. The Empire Gas Works collection can be used to model a complete facility of this type with a Coke Retort (#933-2910) and Gas Plant (#933-2905).

Coal was the life-blood of any gas works and a ready supply was always on hand. Many plants were located alongside waterways, which allowed massive amounts to be delivered by ship. To reach into their holds, Bridge Cranes (#933-2906) with longer booms extending beyond the dock were used. These made quick work of unloading using a large clamshell bucket to stockpile coal nearby.

Many plants received coal by rail and this can be modeled using the HO Gold Line™ USRA 55-Ton 2-Bay Hopper Six-Packs (#932-970 series) which feature 1940s-50s era paint schemes. These same cars often carried loads of coke on the return trip. Tank cars of various types were also used to ship coal tar. To keep cars moving efficiently, many plants had their own small steam, diesel or electric switch engines.

While gas works were often self-contained operations, many were also operated by large industries that required considerable amounts of gas. Your Empire Gas Works kits will be right at home in a steel works equipped with a Rolling Mill (#933-3052), and Coke Oven and Quencher (#933-3053), or a cement plant such as Valley Cement (#933-3098).

For figures, vehicles and accessories to set the scene, ask your dealer, visit our Web-site [waltherscornerstone.com](http://waltherscornerstone.com) or see the latest Walthers HO Scale Model Railroad Reference Book.

**IMPORTANT: You have the option of building a taller or shorter gas storage area. For the taller version use support #'s 2, for the shorter support use #'s 3.**

1. Glue two supports (2 or 3) into the slots in the base (1) by the pad and to the right of it as shown. Insert and glue the lower segment (6) in between the supports and to the base. Note: Segment #6 must be glued in this spot. Next, glue a lift segment (7) above #6 in between the supports.

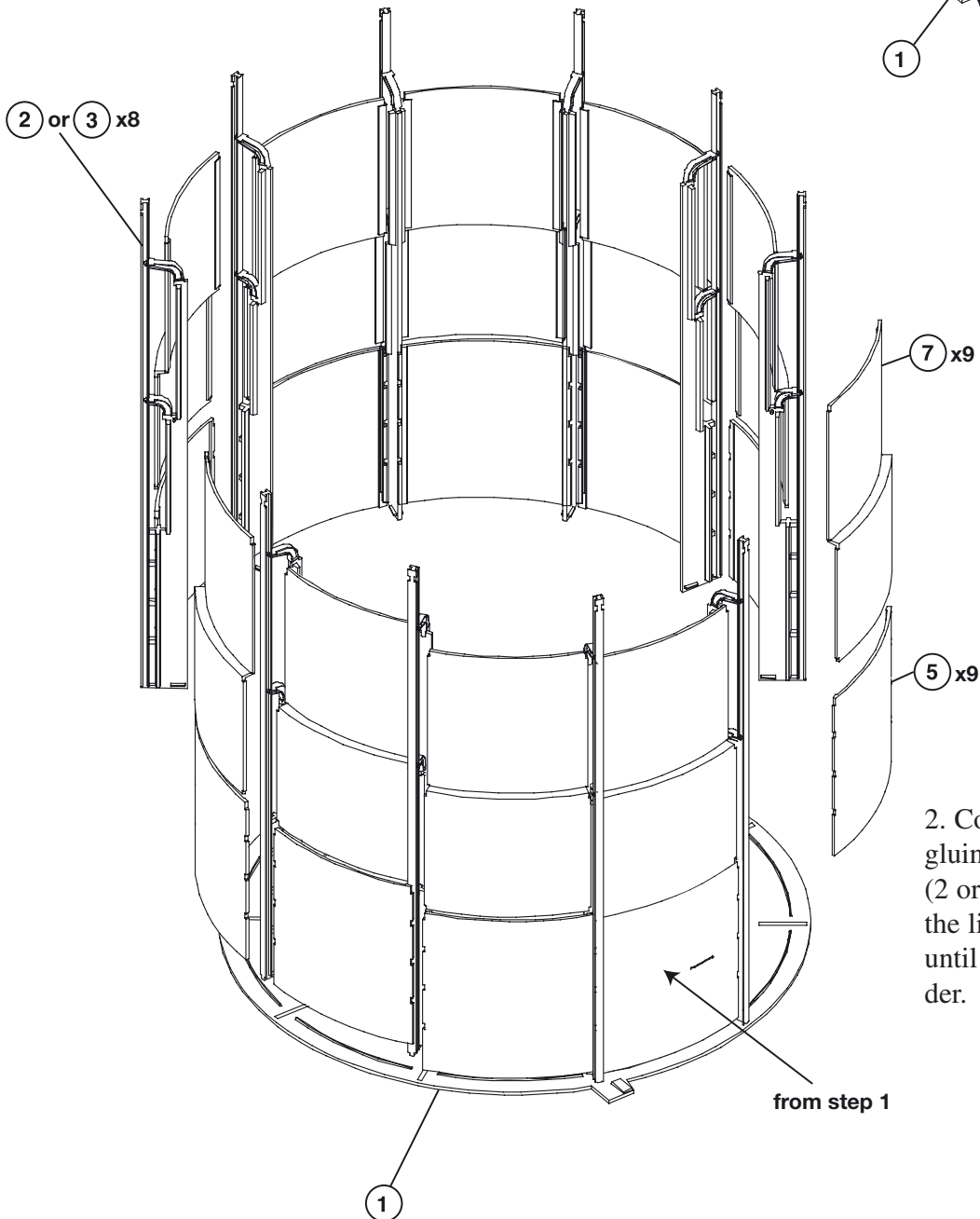
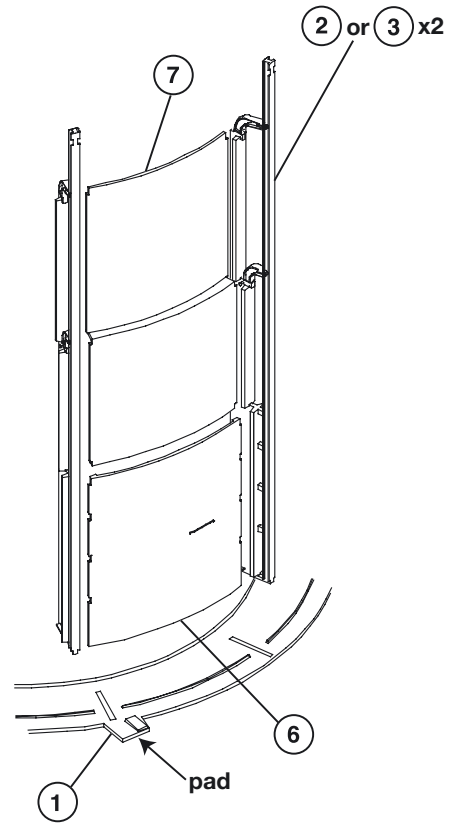

2. Continue around the base, gluing the remaining supports (2 or 3), lower segments (5) and the lift segments (7) in place until you have a complete cylinder.

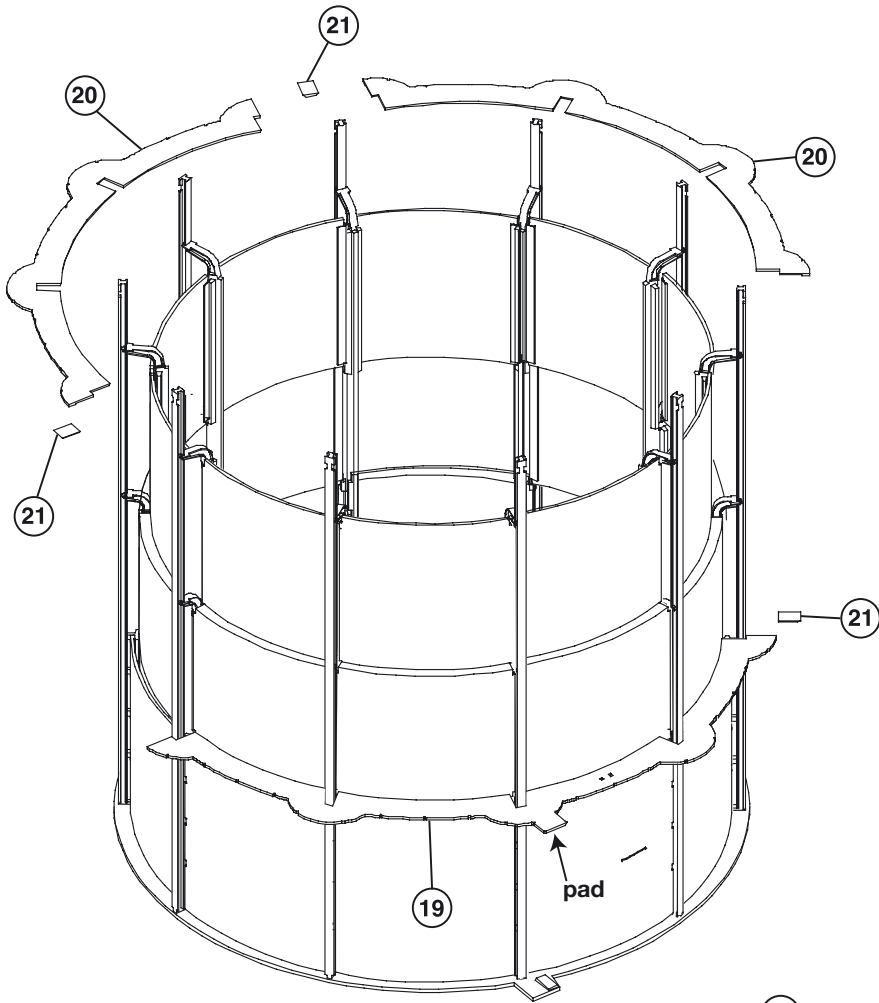

3. Slide the platforms (19, 20) down the supports and glue in place on top of the lower segments. Note: Make sure that the pad on platform #19 is located above the pad on the base. Then glue the splice pieces (21) under the platforms where they meet.

4. Glue the X-bracings (4) to the supports. Note: Line up the top of the braces with the top of the supports.

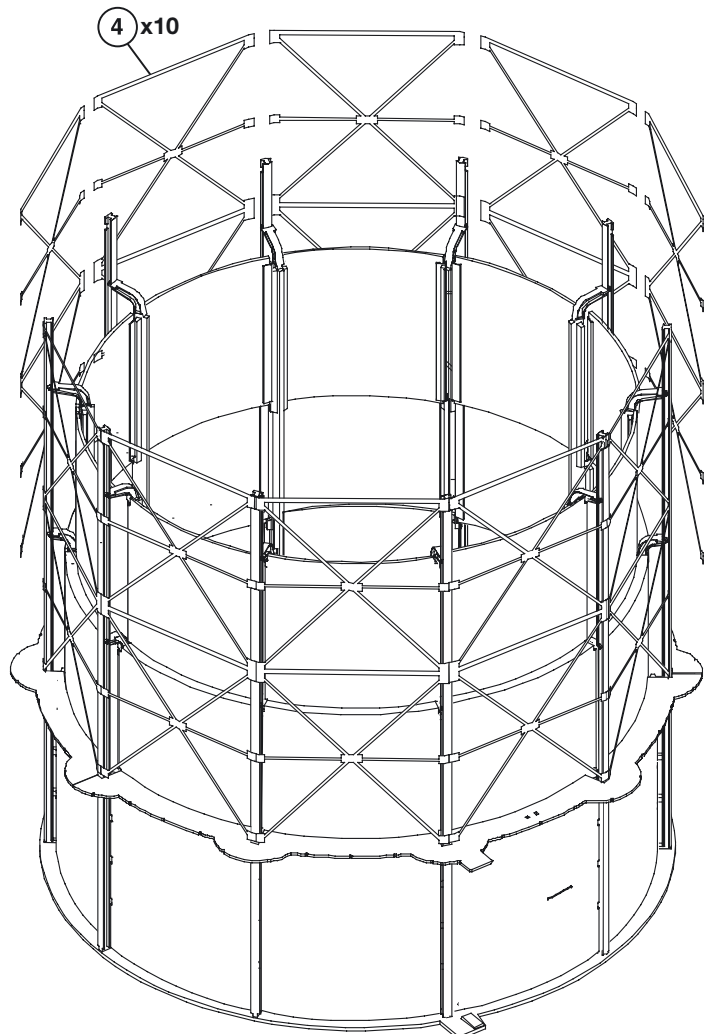

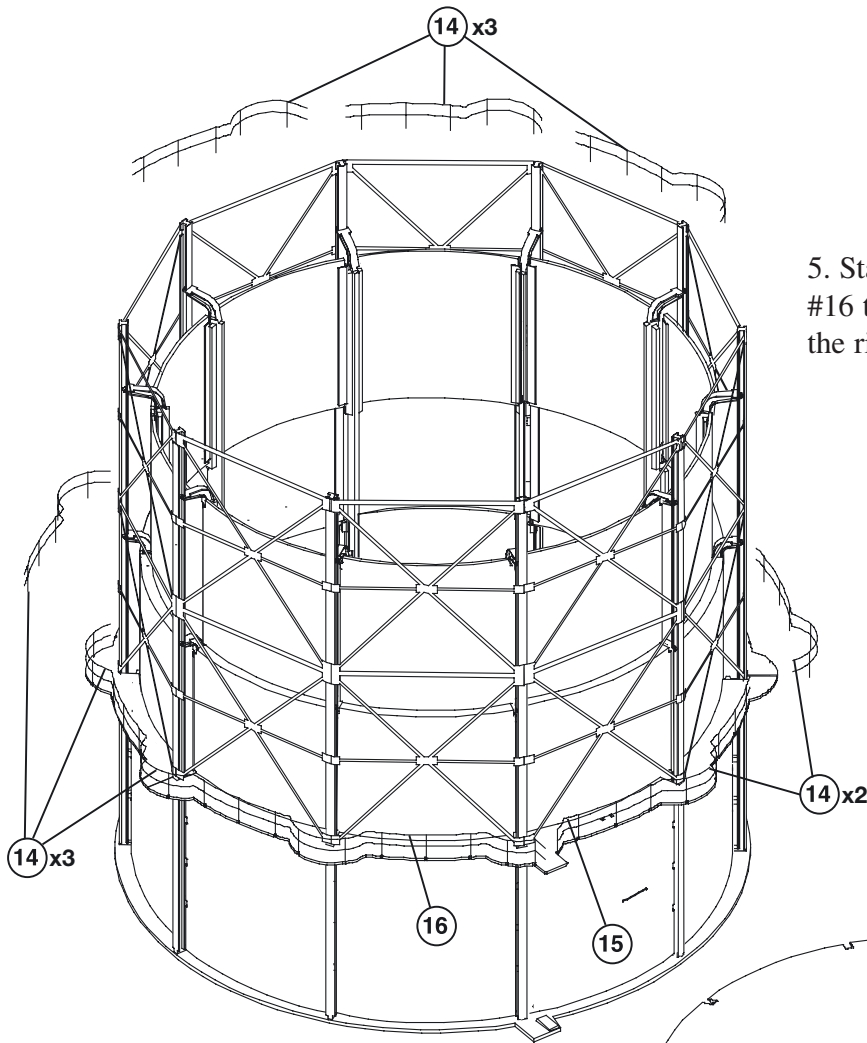

5. Start gluing on the railings with #16 to the left of the pad, and #15 to the right. Then glue on the rest (14).

**NOTE: Picture on box cover shows stairways reversed. The assembly procedure that follows is correct.**

6. Glue the stairs (11) and stair railings (10, 12, 13) together and to the platform (9). Then glue the platform on top of the ridge on the side of segment #6 with the bottom of the stairs on the pad on the base.

7. Glue the ladder (18) into the holes in the platform and also the X-brace. Note: There are pegs on the back of the ladder that will fit around the horizontal beams on the brace.

8. Glue on the roof (17).

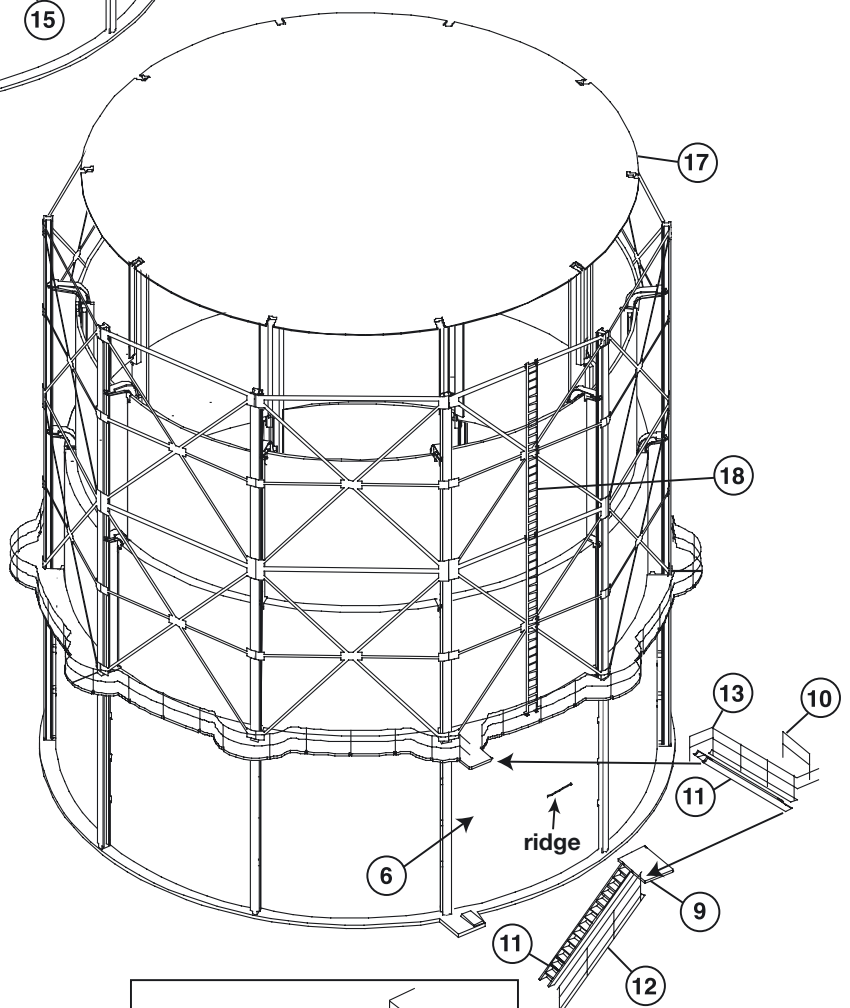

#### SIGNS

To mount signs, simply cut the desired name and, using a small drop of white glue on the back, glue it in place.

notch on top of stairs fits up under pads

